

T-1902

AN EXAMINATION AND EVALUATION OF THE BARRIERS TO SOLAR ENERGY
DEVELOPMENT FOR THE HEATING AND COOLING OF BUILDINGS
WITHIN THE UNITED STATES

by

W. Durand Eppler

ARTHUR LAKES LIBRARY
COLORADO SCHOOL of MINES
GOLDEN, COLORADO 80401

ProQuest Number: 10782079

All rights reserved

INFORMATION TO ALL USERS

The quality of this reproduction is dependent upon the quality of the copy submitted.

In the unlikely event that the author did not send a complete manuscript and there are missing pages, these will be noted. Also, if material had to be removed, a note will indicate the deletion.



ProQuest 10782079

Published by ProQuest LLC (2018). Copyright of the Dissertation is held by the Author.

All rights reserved.

This work is protected against unauthorized copying under Title 17, United States Code
Microform Edition © ProQuest LLC.

ProQuest LLC.
789 East Eisenhower Parkway
P.O. Box 1346
Ann Arbor, MI 48106 – 1346

A Thesis submitted to the Faculty and the Board of Trustees of the Colorado School of Mines in partial fulfillment of the requirements for the degree of Master of Science, Mineral Economics.

Signed: W. Durand Eppler
W. Durand Eppler

Golden, Colorado

Date: April 22, 1977

Approved: J. Paul Mather
J. Paul Mather
Thesis Advisor

J. Paul Mather
J. Paul Mather
Chairman of Department
of Mineral Economics

Golden, Colorado

Date: April 22, 1977

ABSTRACT

At a time of increasing energy consumption in the face of decreasing supplies of conventional energy resources it is becoming critical that alternative energy sources be developed. The utilization of solar energy represents an attractive and plausible solution to this problem. This thesis presents an introduction to solar energy utilization, concentrating on solar energy technologies for supplying the heating and cooling needs of commercial and residential buildings. This application represents the first area where solar technologies may be implemented on a widespread basis and may serve as a test bed for the successful implementation of other solar energy applications. Before focusing on solar heating and cooling of buildings, background information is presented, and other technologies for solar energy utilization are described, evaluating both potential contributions and present limitations. The present solar technologies for supplying space heating and cooling and hot water for domestic use are then described, focusing on the major differences between alternative systems and the general

constraints governing the use of solar energy for this purpose. Once a basis of understanding has been presented, the thesis examines the principal barriers preventing a rapid development of these technologies. These barriers involve social, economic, technical and political constraints, and possible strategies for their removal are suggested in the final section. The principal conclusions found are that solar energy applications for the heating and cooling of buildings will be developed as the cost of fossil fuels increase relative to price reductions in solar energy equipment, due to increased productization and economies of scale. At the same time, the rate of implementation will be primarily affected by the degree of governmental involvement in creating additional incentives for development.

TABLE OF CONTENTS

	<u>Page</u>
Abstract -----	iii
List of Illustrations -----	vii
List of Tables -----	viii
Acknowledgements -----	ix
Chapter 1. Introduction -----	1
Chapter 2. Background -----	6
Chapter 3. Solar Energy Technologies -----	22
Solar Thermal Power Production -----	22
Ocean Thermal Power Systems -----	29
Photovoltaics Power Systems -----	35
Electrical Generation from Wind Power -----	41
Bioconversion to Fuels -----	45
Energy Storage Systems -----	54
Integrated Systems -----	61
Small-Scale Utilization of Solar Energy -----	65
Chapter 4. Solar Energy Technologies for the Heating and Cooling of Buildings -----	68
Passive Collecting Systems -----	71
Active Collecting Systems -----	74
Collector Design -----	75
System Efficiency -----	83
Solar Water Heaters -----	85
Sensible Heat Storage -----	89
Heat-of-Fusion Storage -----	90

<u>Table of Contents</u> continued	<u>Page</u>
Solar Cooling Systems -----	91
Combined Systems for Heating and Cooling -----	94
Economics -----	77
Chapter 5. Barriers to Utilization of Solar Energy for Heating and Cooling of Buildings -----	102
Social -----	102
Technical -----	109
Economic -----	110
Political -----	113
Chapter 6. The Outlook for Solar Energy: Strategies for Development -----	117
Literature Cited -----	131
Bibliography -----	138
Books -----	138
Periodicals -----	138
Public Documents -----	140

LIST OF ILLUSTRATIONS

	<u>Page</u>
Figure 1: Relative Intensity of Different Wave-lengths of Solar Energy -----	7
2: Projected U.S. Energy Demand by Source -----	18
3: Total U.S. Gross Energy Use, 1973 -----	20
4: Solar Thermal Conversion Concept -----	24
5: Parabolic Cylinder Mirror -----	25
6: Spherical Reflector Tracking Mirror, Cross-section -----	25
7: Typical Aeroturbine Design -----	42
8: Bioconversion of Fuels--Energy Systems -----	51
9: Diagram of a Solar Energy System for the Near Future -----	63
10: Diagram of a Solar Energy System for the Long-Term Future -----	63
11: Typical Solar Collector, Cross-section-----	76
12: Examples of Solar Water and Air Heaters -----	81
13: Thermosyphon Water Heater -----	86
14: Schematic Diagram of Thomason Solar Home -----	95
15: Integrated Design for Solar Heating and Cooling -----	97
16: Technology Delivery System for Solar Energy--	120
17: Technology Delivery System for Solar Energy Showing Possible Incentives -----	128

LIST OF TABLES

	<u>Page</u>
Table 1: Solar Cell Materials and Theoretical Efficiencies -----	36

ACKNOWLEDGEMENTS

I would like to take this opportunity to thank the members of my thesis committee, without whose constant admonitions about the A.B.D. (All-But-Dissertation) Degree, this thesis might not have been written.

Dr. Jean Paul Mather, Advisor
Dr. Austin R. Brown
Dr. Huntington Swanson
Dr. Frank Mathews

CHAPTER 1. INTRODUCTION

The tremendous power of the sun has always been a source of fear and admiration to mankind, and he has tried for many centuries to harness it to suit his needs. In general, these have been small scale, expensive attempts, and therefore not applicable to society's demands for cheap and abundant power. With the increasing scarcity and higher cost of conventional fuels, the need for developing alternate energy sources has become especially critical. This has spawned a renewed enthusiasm for solar energy development on a broad scale. This enthusiasm, however, is not universal. A wide spectrum of opinion exists concerning the extent to which solar power can satisfy our energy needs. On one hand the public believes that solar energy is a panacea, the final solution to our energy problems; while on the other, many public power utilities have relegated the possibility of solar energy development to the far distant future. These extremely divergent opinions exist because of a general ignorance of the possibilities and limitations of solar energy utilization. Therefore, the

primary objective of this thesis is to give the reader an introduction to solar power development.

This document is geared to the uninitiated reader, with no previous knowledge of solar energy, and endeavors to establish a common base of information so that the possibilities of solar energy development can be discussed from a standpoint of knowledge rather than ignorance.

Chapter 2, "Background", introduces the reader to the subject by presenting an idea of the size of the solar resource, and then outlines some of man's early attempts to utilize the rays of the sun.

Chapter 3, "Solar Energy Technologies", is designed to set out the operating principles, prospects, and limitations of the various solar energy applications. By thus describing the 'State-of-the-Art' it is hoped that a common groundwork can be established as a basis for further discussion.

The remainder of this thesis, Chapters 4, 5, and 6, is concerned with the application of solar energy technologies to accomplish space heating and cooling, and to supply the hot water needs of commercial and residential buildings. The reason for an in-depth analysis of this solar technology is that the heating and cooling of buildings represents the most immediately feasible application of solar energy,

which is already being developed on a limited scale. The technology for solar space heating and cooling and hot water largely exists, with very few technical problems preventing solar energy from making a substantial contribution to this energy demand. In addition, solar energy striking the earth is diffuse, and thus well suited to the task of supplying the low temperature heat needed for water and space heating. This sector currently accounts for 25 percent of the United States' annual energy consumption, and represents an area where a major saving of conventional fuels can be effected. A successful implementation of solar energy technologies to this area would also make a positive contribution toward enhancing and accelerating the development of other solar technologies. Thus, because this will be the first widespread use of a solar technology, and will have an important effect on the rate of future utilization, it is important to focus on the problems associated with the implementation of this new technology.

Although the tremendous potential for solar heating and cooling has long been recognized, the United States has moved very slowly toward this end. While inexpensive fossil fuel prices had long prohibited the development of higher cost solar systems, as fuel prices have risen dramatically it has been apparent that barriers other than fuel

costs exist to solar energy development. In order to speed the development of solar technologies these barriers must be identified and replaced with positive incentives to development. While perhaps the strongest incentive to increased utilization will be the rising trend in fuel prices, affirmative action by individuals and institutions will greatly encourage the movement toward a solar alternative.

Chapter 4 serves as an introduction to this subject, and describes the various technologies which can be applied to heating and cooling of buildings, in an attempt to have the reader understand the specific problems which exist in this solar application. Proceeding from this framework, Chapter 5 sets out to identify the principal barriers to development of this alternative. These are not limited to technical or economical concerns, but incorporate social and political spheres as well. Their resolution will be the principal determinant of the rate at which this technology is developed. From this identification of potential barriers, Chapter 6 presents the concept of a Technology Delivery System (TDS), whereby the principal determinants of the rate of technological implementation can be examined. In this way specific incentives can be identified and applied to specific blockages at several points of the TDS with the overall effect of significantly improving the climate for solar energy utilization.

In conclusion, it is seen that the principal role in accelerating solar energy development will be played by the Federal Government. It will be the willingness of governmental institutions to encourage and support solar energy development by creating the necessary incentives that will primarily determine the rate of technological implementation.

CHAPTER 2. BACKGROUND

The source of all life on the planet Earth is the sun, a huge nuclear fusion reactor located variably between 91.33 million miles from the Earth in late December and 94.48 million miles in late June. (1) The sun is approximately average in size and temperature and is classified as a yellow dwarf among stars. Temperatures vary from an estimated 10 - 20 million degrees Kelvin in the center to about 6,000 degrees Kelvin at the cooler parts of the surface. (2) Our sun consists of about 70 percent hydrogen and 28 percent helium, and the thermonuclear fusion of hydrogen to produce helium is the source of solar energy.

Solar energy reaches the outer atmosphere of the Earth in the form of electromagnetic radiation with wavelengths varying from x-rays of 0.1μ to radio waves 100 meters long. This radiational pattern corresponds closely to that of a perfect radiator or "blackbody" heated to 6,000 degrees Kelvin, as shown in Figure 1 (dashed line). (3) In spite of this very wide range, the vast majority (99 percent) of the sun's energy is contained in a much smaller band of

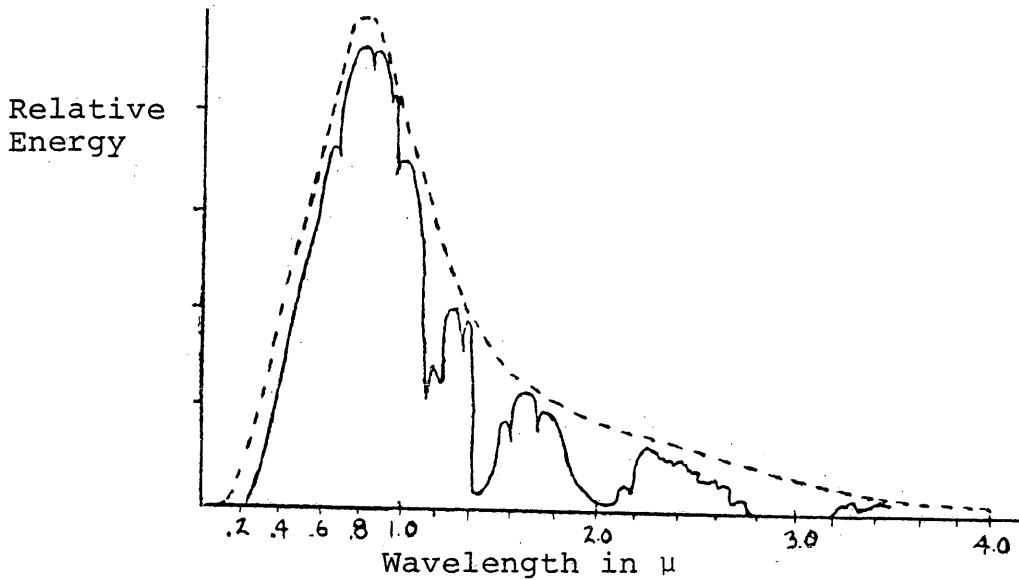

Figure 1: Relative Intensity of Different Wavelengths of Solar Energy

radiation, between 0.28μ and 4.96μ . (4) The intensity of solar radiation striking a surface normal to the sun's rays beyond the limits of the Earth's atmosphere at a distance of one astronomical unit from the sun (92,955,888 miles) is defined as the solar constant. This value has been calculated by several sources, and is currently estimated to be 135.8 mW/cm^2 (milliwatts per square centimeter). This is equivalent to 1.94 Langleys/minute, ($\text{cal./}(\text{cm})^2\text{min.}$), in the language of meteorologists, or to 429.2 Btu/ft.²min. in the language of the United States heating and cooling industry. (5) Due to the elliptical nature of the Earth's orbit around the sun, the value of the solar constant fluctuates

during the course of the year. Because the intensity of solar radiation varies inversely as the square of the distance from the sun, the value for the solar constant "varies from 139.9 mW/cm² on January 1 to 130.9 mW/cm² on July 1." (6)

While the solar constant measures the solar radiation incident at the boundaries of the atmosphere, it is not necessarily an accurate measure of the solar radiation available for man's use. A more accurate picture of the solar radiation reaching the Earth is seen in the solid line in Figure 1. The shorter wavelength, ultraviolet, and x-rays less than .2 μ are absorbed by oxygen and nitrogen and "most of the radiation from .2 μ to .3 μ is absorbed by ozone in the outer atmosphere." (7) In the red and infrared portions of the scale there are "prominent absorption bands...from the passage of the light through carbon dioxide...and water molecules." (8) These water molecules, in the form of droplets and vapor, not only absorb some of the longer wavelength radiation, but scatter the radiation of shorter wavelengths. In addition, certain local climatic conditions, such as haze, air pollution and dust, as well as cloudy weather, may greatly affect solar insolation. The resulting solar radiation which finally reaches the Earth's surface may vary between 1.5 and 0 Langley/min. (9). Although most of this radiation comes directly from the sun, as much as 10 percent may come as scattered light, even when the sun

is unobstructed by clouds. During periods of cloudy weather almost all of the solar radiation reaching the Earth may come as scattered or diffused light. Furthermore, the diurnal and seasonal variations caused by the Earth's rotation and tilted orbit around the sun account for major changes in solar insolation. These climatological factors have a major influence on our potential utilization of solar energy.

This incoming solar radiation which reaches the surface of the Earth, although variable and of low intensity, provides and supports all life on our planet. Stored solar energy, in the form of fossil fuels, oil, gas, and coal, has enabled the rapid growth of our industrialized society, and together with hydroelectric energy (another form of stored solar energy) these sources provided almost 100 percent of our 1974 energy consumption of 75 quadrillion Btus in the United States.* (10) This amount of societal consumption is almost inconsequential compared to the utilization of solar energy by other life and Earth processes. Photosynthesis, the process by which we are provided with food, fiber, wood, and beautiful scenery, consumes about 100 quadrillion Btu in converting solar energy to plant matter within the United

*1 quadrillion Btu = 10^{15} Btu; is equivalent to roughly 40 million tons of coal or 180 million barrels of oil or 1 trillion cubic feet of natural gas.

States. But because plants must transpire about 500 pounds of water to make one pound of dry plant matter, the energy required is much greater, and the "solar energy input for this evapotranspiration is on the order of 10,000 quadrillion Btu, or 20 percent of the energy falling on the United States each year." (11) A solar energy utilization of about 13,000 quadrillion Btu is also responsible for the evaporation (and desalination) of seawater, which provides "most of the 30 inches average annual rainfall in the United States." (12) This rainfall is used for direct consumption, provides fresh water for our lakes and rivers, and enables the plants to maintain their transpiration processes.

These numbers demonstrate not only the extent of our dependence on solar energy, but also the immensity of solar radiation as a potential source of usable power. Also, what we as a nation consider to be our national energy budget is in reality only a very small fraction of our total energy dependency, all of which is supplied, in one form or another, by the sun's energy.

In spite of the fact that solar radiation supplies the energy for the continuance of all of our life processes, and has made an industrialized society possible, based on the use of stored solar energy, man's attempts to utilize solar energy directly have been relatively limited. Hunting and farming were probably the first areas where man actively

utilized the sun, for the drying of food and animal skins. An acknowledgement of the importance of solar energy must have been present as early farmers learned about climatic conditions and growing seasons.

Perhaps the first use of a solar device was by Archimedes, the Greek experimenter, in 212 B.C. in defense of the city-state of Syracuse. According to Galen (130-200 A.D.), Archimedes directed soldiers to use their shields to focus the sun's rays as a primitive solar collector to burn attacking Roman ships. In spite of his innovative technology, the Greeks lost the siege and Archimedes did not survive the sack of the city.

In early scientific experiments, solar focusing collectors were used to smelt metals, and one such parabolic reflecting mirror survives from the mid-17th century.(13) Joseph Priestly, in 1774, used a solar concentrating device to heat mercuric oxide and collected the gas, thus discovering oxygen. With these findings, and his own experiments using a similar solar furnace, Lavoisier was able "to propound the correct theory for combustion as caused by combination with oxygen."(14)

The virtue of using concentrated solar energy in scientific research is that very high temperatures can be produced with a great deal of purity, free from the emissive by-products

of conventional heat sources. The solar furnace at Odeillo, France is a modern example of solar energy used for scientific and industrial research. This furnace uses a series of 63 flat reflecting mirrors which "automatically track the apparent motion of the sun and reflect the incident radiation onto a fixed parabolic reflector." (15) The parabolic reflector is composed of 9,400 mirrors, which concentrate the sunlight onto a small focal point where temperatures as high as 3,800°C have been created.

An early and surprisingly large-scale use of solar energy was in 1872 in the desert of northern Chile, where a solar still covering 51,000 square feet was used to produce fresh water for a nitrate mine. The still consisted of shallow trays covered by glass roofs which were filled with salt water. Incoming solar radiation heated the water in the trays, and the vaporized water condensed on the underside of the aircooled glass roofs and ran down into collecting channels. The solar still produced up to 6,000 gallons of water per day and operated throughout the forty-year life of the mine.

The ability of directly utilizing solar energy to do work was further demonstrated by many experimenters, mostly American and French, around the turn of the century. Several collector designs were developed whereby steam was generated

to run engines. One large scale experiment was conducted by two Americans, F. Shupman and C.V. Boys, who developed a solar powered engine capable of generating 50 horsepower. The engine was built near Cairo, Egypt in 1913, and used long parabolic cylinders which focused solar energy onto a central pipe where water was heated. The engine was used to pump irrigation water from the Nile River, but operated for only a short time, as it became difficult to obtain replacement parts.

Although some important research for solar house heating and collector design was carried out at M.I.T. during the 1930's under the auspices of the Cabot Fund, there was relatively little activity in the solar energy field during the 1920's-1940's. This was primarily because of the abundance of inexpensive fossil fuels, which made solar energy an economically unattractive alternative, and which discouraged further research. The 1950's, however, saw a revival of interest in solar energy, and several symposia and scientific meetings were devoted to the potential of solar energy. The Association for Applied Solar Energy (now the Solar Energy Society) was organized in 1955. In addition to the rekindling of interest in the scientific community, solar products in the form of water heaters began to find markets in several countries, notably Israel, Australia, and the

United States. The use of solar water heaters within the United States was largely in Florida, where there was abundant sunshine and where natural gas was unavailable. It is estimated that 20,000 homes in Florida used solar water heaters, but when cheap natural gas became available in the early 1960's, the use of the solar systems declined.

Among the scientific community, interest and commitment to a more widespread use of solar energy has continued through the present, in spite of the limited acceptance and utilization which solar energy products and systems have found among the public. With few exceptions, then, the direct use of solar radiation has been characterized by small-scale, individual applications where economic considerations were not of primary importance.

There is, however, sound reasoning behind the hopes and aspirations of the proponents of solar energy. According to the National Petroleum Council and the National Science Foundation, solar energy is our largest potential energy supply, dwarfing the recoverable energy estimates for the fossil fuels and uranium resources. Furthermore, solar energy is ubiquitous; it falls everywhere, where no cartel can touch it. It has been termed our "free" energy source, and there is essentially no pollution associated with its use, a problem which places severe doubts on the future use

of nuclear and other fossil fuels for power. Solar energy is also particularly well suited to smaller-scale, decentralized applications, and as such, may find its first wide-scale applications within developing countries where the need for intermediate technologies is the greatest. It is easily adaptable to individual locations and needs (provided there is sunlight), and is a primary alternative for power in areas where there is no electricity, or where transportation facilities bringing in fossil fuels are unreliable.

In spite of the obvious attractiveness of solar energy as an energy source, it has not developed to any large degree. This, in part, is due to the intermittent and variable nature of solar radiation. While solar radiation may achieve very high levels during the middle of the day, at night it falls to zero, and local weather, haze, and dust may greatly reduce insolation even on relatively sunny days. Because of the low intensity of the solar radiation reaching the Earth, collectors or concentrators must be employed to convert this light energy into mechanical energy, requiring expensive equipment. The diurnal nature of solar radiation requires that some means of storage be included, and this, too, is expensive. Solar energy systems, then, are characterized by very high initial and correspondingly low operating costs, the energy input being free once the equipment is installed. Thus, it is economic reasoning based on a high initial, low operating, cost for solar energy, and low initial, relatively low

operating cost for conventional power systems which has given the edge to conventional fuels, and resulted in the economic unattractiveness of solar energy.

In the past five years, this balance has begun to change rapidly, with increasing importance being given to the solar energy resource. With the Arab Oil Embargo of 1972, the world community, and especially the industrialized nations, began to realize its alarming dependence on cheap and plentiful fossil fuels, much of which come from foreign sources. Coupled with the reality of an oil embargo was the emerging public awareness of the finitude of fossil fuel reserves and declining national production. Within the United States production of crude oil peaked at 9.6 billion barrels in 1970, and has declined slightly since to about 8.9 billion barrels in mid-1974.(16) In addition, the United States was importing oil at the rate of 6.5 million barrels per day, and energy imports are seen as a major factor influencing our balance of payment deficit. The same is true for domestic natural gas supplies, for in many areas of the country no new hookups are allowed, and distributors are uncertain as to whether they will be able to deliver gas beyond the next two or three years. Shrinking fuel reserves, in the face of rapidly increasing demand and high inflation, have made the costs of finding, producing, and purchasing conventional fuels rise at unparalleled rates. Nuclear power, too, has

not yet provided the answer that was hoped for. Once claimed as the ultimate answer to the nation's energy needs, rising costs of nuclear fuels and nuclear reactors, coupled with violent environmental controversies, have greatly delayed its widespread utilization and changed its economic attractiveness. Public resentment at the higher costs of conventional energy has led to a re-evaluation of how our dollars should be spent for energy. This has awakened a new interest in the potential for solar energy, which is now becoming economically attractive.

An increasing predisposition to solar energy is economically sound, not only because of its cost competitiveness with conventional fuels, but also from a conservation standpoint. Annually increasing demand (Figure 2) (17) will lead to more expensive fuel costs as it becomes more difficult for supply to satisfy demand, and conservation of existing supplies will become more important. In an attempt to try to prepare for the future and head off this supply and demand crunch, the United States began a large-scale movement towards establishing energy self-sufficiency in early 1974. "Project Independence" had as its goal both the establishment of conservation measures and the development of alternative energy supplies, including solar, geothermal, coal gasification, and development of oil shale and tar sands deposits

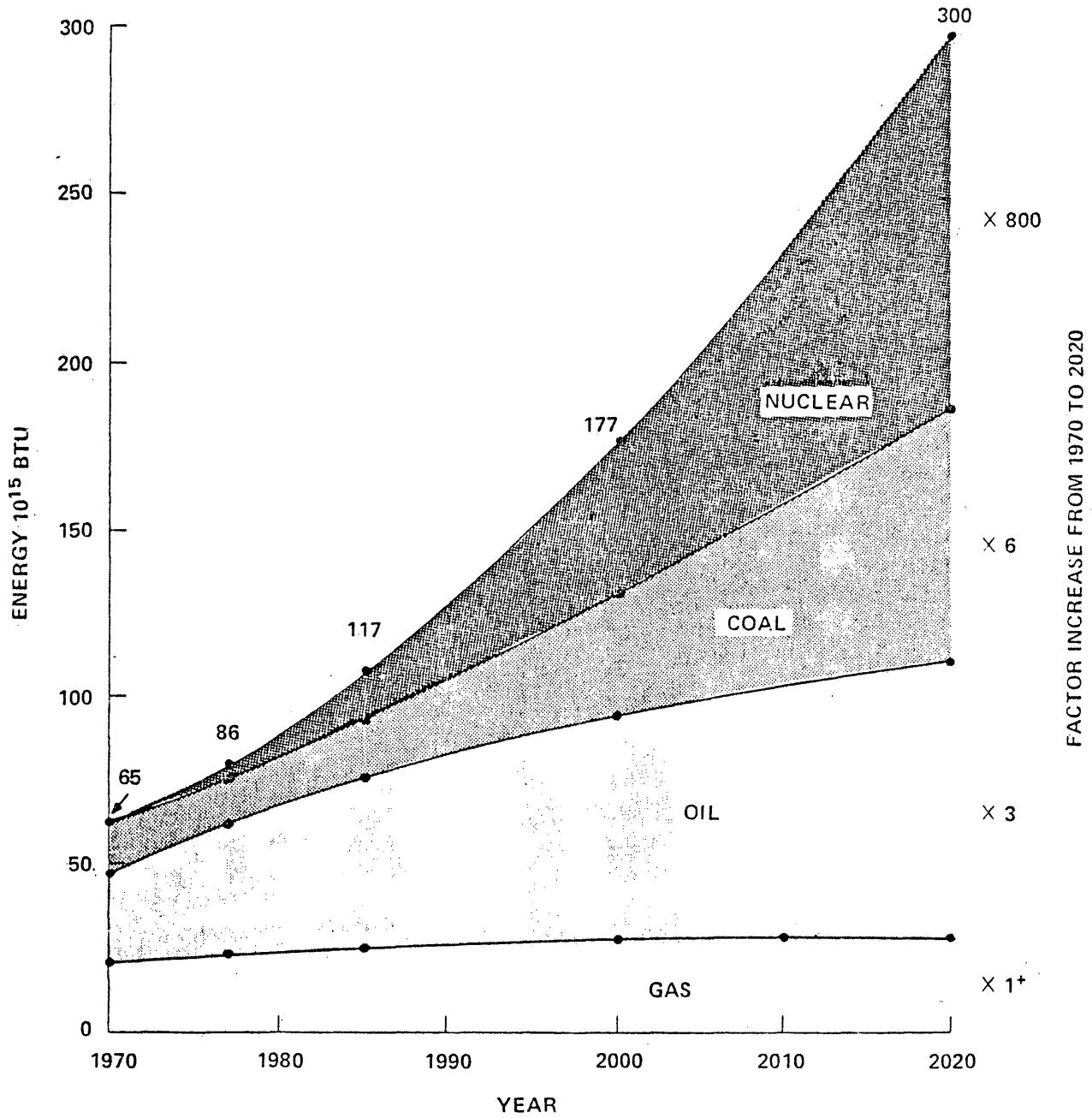

FIGURE 2. PROJECTED U.S. ENERGY DEMAND BY SOURCE

for the production of oil and natural gas. The Final Task Report for Solar Energy established that utilization of existing solar technologies could supply a significant amount of this future demand.

For example, one area where solar energy will have its greatest immediate impact will be in providing low temperature heat in the form of hot air and water in temperatures from 90 to 200 degrees Fahrenheit, which can be used in the heating and cooling of buildings, and for providing hot water for home use. Already in 1973 this demand accounted for 25 percent of our national energy consumption of almost 75 quadrillion Btu (see Figure 3). (18) A widespread move towards the utilization of solar technologies for home hot water, space heating and cooling would result in tremendous savings of diminishing fossil fuel reserves.

The potential of solar energy to meet future energy demand is by no means limited to the heating and cooling of buildings, although it is generally regarded that the first widespread uses will occur here. (19) Several well developed concepts for the utilization of solar energy exist, which, when applied, could further enable a large fuel savings. The methods for generating solar power include wind power systems, electricity from photovoltaic cells, fuel production from bioconversion, and power generation from both solar thermal processes and ocean thermal gradients. Each of

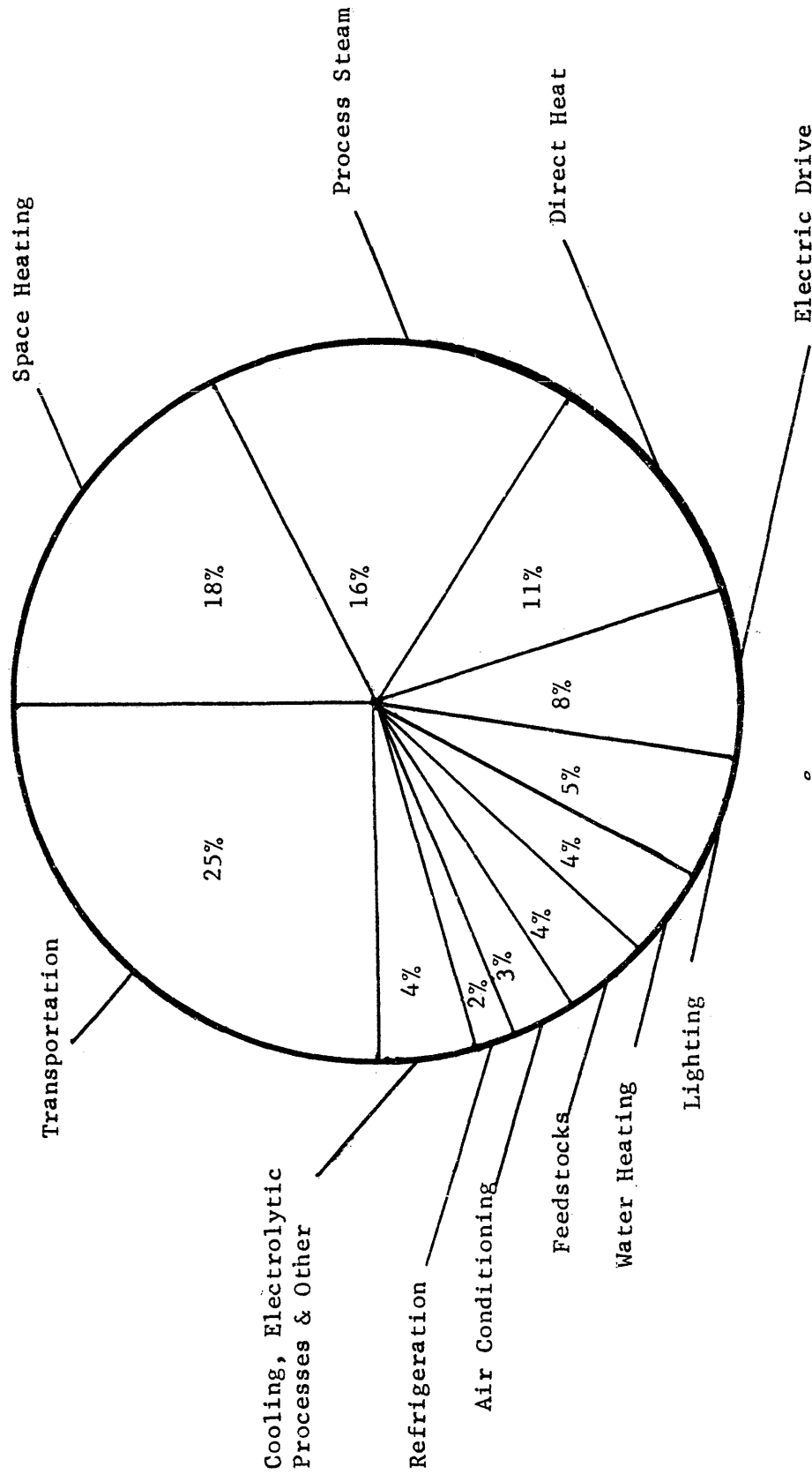

FIGURE 3. Total U.S. Gross Energy Use, 1973

these technologies will be described briefly in the next section. The potential contribution of each of these solar technologies is great, although eventual utilization is dependent on the successful operation of experimental pilot plants which can be scaled up to an economically attractive size.

An important point to note, which will greatly aid the development of these solar technologies, is that for the first time within the United States the federal government is beginning to actively support and fund their development. In the 20 years between 1952 and 1972 total government support to solar energy was less than \$25 million. In 1973 alone, federal aid was \$4 million, and the fiscal 1977 budget calls for \$160 million, an increase of 40 times in 4 years. (20) This rapid move into solar energy on the part of the government is demonstrative of not only the need for alternative energy sources, but also increasing attractiveness of clean solar energy and widespread public support of this alternative. It may well be this broad based support, both political and financial, which clearly establishes solar technologies as economical alternatives on a large scale. Thus, in spite of many years of frustrated past enthusiasm for solar power, it appears that its time is approaching, and changing economics are providing the primary motivation.

CHAPTER 3. SOLAR ENERGY TECHNOLOGIES

Solar energy can, in principle, meet any of the energy needs now supplied by conventional fuels. The application of solar energy can be classified into three broad groups: "1) the heating and cooling of buildings, 2) the chemical and biological conversion of organic materials to liquid, solid, and gaseous fuels, and 3) the generation of electricity." (21) As pointed out in the previous section, the application of solar technologies to any of these areas will result in important conservation of fossil fuels. The present section is designed to acquaint the reader with the basic concepts and technologies for solar energy utilization so that a greater appreciation for the problems involved with the use of this power source will be reached.

Solar Thermal Power Production

Large scale solar power electric generating stations represent a solar application which will permit conservation of considerable amounts of fossil fuels. Possible economies of scale in large installations both land and ocean based,

add to the economic attractiveness of these technologies, and may improve their competitive position with conventional power sources. The technology for constructing large land-based solar thermal power stations exists, although excessive capital costs and lower efficiencies than in conventional sources have prevented development of this technology to date.

Conventional fuel powered generating plants are based on the conversion of chemical or nuclear energy derived from the fuel into heat energy, which is then used to produce steam and power a turbogenerator, thus producing electricity. Several designs for producing electricity from solar energy are based on this technology. Incoming solar radiation is typically collected concentrated, and converted into heat energy, which is used to generate steam by means of heat exchangers to drive the steam turbine. A location with high annual solar insolation and large land areas, such as the southwestern United States, is desirable. Unfortunately, though, such a power plant requires great amounts of cooling water, which is lacking in the Southwest. Therefore:(22)

Designs which concentrate the solar heat at high temperatures (with the associated high efficiencies for converting heat energy into electrical energy), and designs involving rejection of waste heat directly to the air would be favored.

In addition, because of the diurnal variation in the solar insolation, some system for energy storage must be included in system design. The concept for solar thermal conversion is diagrammed below: (23)

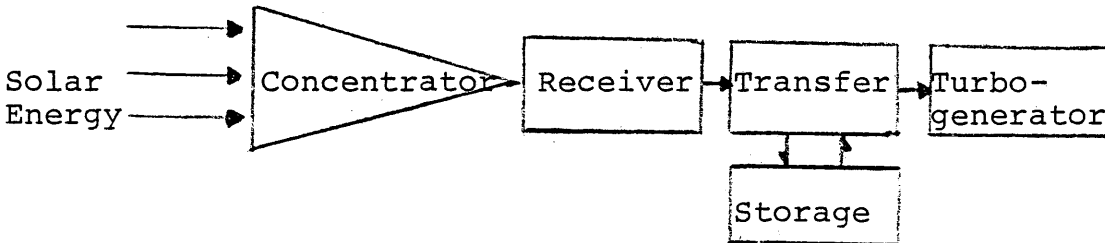

Figure 4: Solar Thermal Conversion Concept

Another common feature of such systems is that in order to maintain sufficiently high temperatures, some type of concentrating collector must be employed which is capable of tracking the sun, thereby allowing for the maximum use of the sun's direct rays.

Because the methodology for the electrical power production using steam driven turbogenerators is well developed, the major differences between solar thermal technologies are in the collection-concentration design and specifications, all of which have a direct effect on the cost of energy collection. One design which was demonstrated in commercial operation in Egypt in 1913 is the parabolic cylindrical mirror (PCM). In this model "the mirror is formed by linearly extending a plane parabola perpendicularly to the plane of the parabola." (24) (See Figure 5). In this manner a

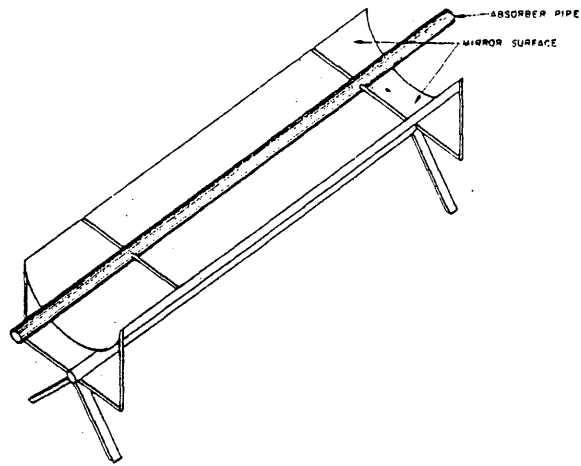

Figure 5: Parabolic Cylinder Mirror

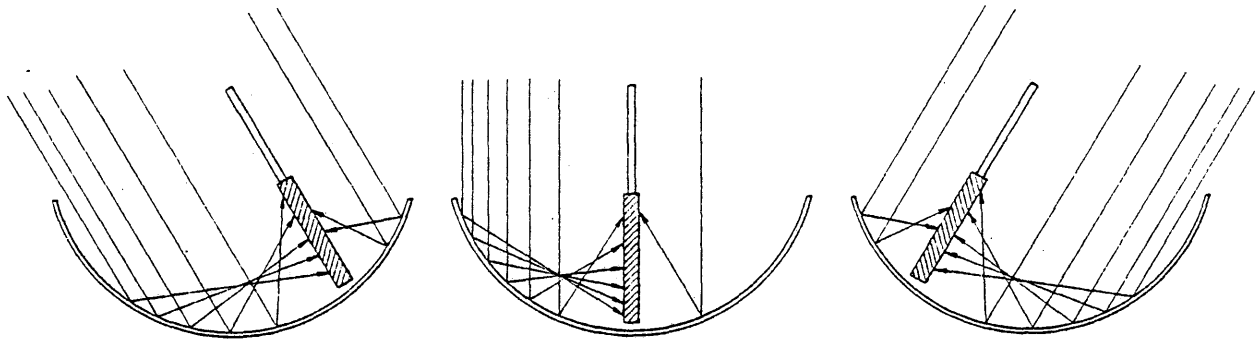

Figure 6: Spherical Reflector Tracking Mirror, Cross-section

parabolic trough is formed which focuses the plane sun's rays to the parabola's focal point, where an absorber pipe transfers the sunlight to heat energy using a working fluid, typically water. An advantage of this design is that it requires no daily adjustment in the mirror position if the collector is oriented along an east-west axis, the collector needs only to be periodically tilted to account for the apparent seasonal variation in the sun's north-south position. Other designs of PCM's have been oriented on a north-south axis, and tracked the east-west movement of the sun by means of simple rotation of the entire mirror.

Collector performance is measured by the concentration ratio, which Maddox defines as "the light intensity of the focal area divided by intensity intercepted by the mirror plane;" it is determined by mirror precision. (25) Whereas, ideally the concentration ratio of a perfect PCM approaches infinity, mirror performance is much lower in practice. This is because a focal area of reasonable size is necessary (not a mathematical point in space), and because there are technical and economic limits to the construction of mirror surfaces which can withstand exposure to the weather and perform satisfactorily over a long service life. As an example, the PCM used in Egypt had a concentration ratio of about 4.5. While higher ratios are possible with today's PCM's, they are still moderate because a large absorber area is needed if the system is to avoid the need for tracking the sun.

Another concentrating collector which does not require constant mirror adjustment is the Spherical Reflector Tracking Absorber (SRTA). This collector is based on a stationary spherical mirror in which the absorber plate moves to stay within the focal point of the mirror (see Figure 6). The tracking movement of this absorber plate is a much less difficult engineering problem than the tracking motion of the entire mirror, and makes the SRTA an attractive design from an economic standpoint. Maddox and others have calculated that high concentration ratios are possible (ranging from 30 to 100) and that steam at 1,000°F and 1,800 psi can be achieved with the SRTA collector system. (26)

A third and widely publicized design for utilizing solar thermal energy employs a large area covered with heliostates, or flat mirrors, which reflect the incident radiation to a central receiving absorber tower which is illuminated by all the mirrors. Although each of the heliostates must be individually motorized and precisely aligned to reflect the sunlight to the absorber tower, very high concentration ratios are possible. In spite of the higher cost of utilizing heliostates, several advantages are realized with this method. (27) First, because the electrical generating equipment can be very closely located to the absorption tower, heat transfer distances can be minimized, and energy

efficiencies increased. Second, by transmitting light rather than a fluid to a central location, many plumbing connections can be avoided, and maintenance and construction costs considerably reduced. Furthermore, with the use of a large field of heliostates the entire system is not critically dependent on each mirror, and can operate successfully if several of the heliostates were malfunctioning or under repair. A final advantage of this design is that the heliostates would seem to be well adapted to mass production economies whereby initial costs might be reduced. Several designs for a central power plant using heliostate reflectors have been proposed, and a pilot program has been initiated. Although costs must necessarily run high in the development of innovative technologies as engineering problems are solved, there is good reason to expect that such large scale power plants will become economically competitive with conventional plants as the concept is established and while competitive plants as the concept is established and while competitive fuel sources increase in price.

The utilization of solar thermal technologies is dependent on the availability of large land areas. It has been established that a 1,000 megawatt (MW) power plant located in the Southwest would require "a collector area of about 15 square miles if it could convert the incident solar energy

to electricity at an overall efficiency of 10 percent."(28) Although theoretical efficiencies of 20-30 percent have been estimated, it seems to be unlikely that overall efficiencies much greater than 10 percent will be achieved.(29) While at first glance a land requirement of 15 square miles seems very large, it is not out of line with other power production land requirements. Reservoirs for hydroelectric power plants often exceed this area, and it is estimated that a coal-fired power plant with a 30 year life of similar size (1,000 MW) would require an equal amount of land to be surface mined if the coal seam averaged 7 feet in thickness.(30)

Energy storage is a major requirement of solar thermal power plants, and the high cost of efficient energy storage systems has, along with the cost of collectors, been a major factor contributing to the economic unattractiveness of this energy alternative. While the various technologies for energy storage will be discussed later, it is sufficient to say that a widespread development of solar thermal power is dependent on reducing the costs of energy storage systems and developing economies of scale to cut the costs of collectors.

Ocean Thermal Power Systems

While land based technologies for solar thermal development have received considerable attention, less publicized concepts exist for energy production from thermal gradients

in tropical or subtropical seas. Although difficult engineering problems exist in developing a potential ocean thermal plant, the concept is well established. The high cost of constructing such a power station in light of cheaper conventional alternatives has, until now, prevented this alternative from being further explored.

The concept for using ocean thermal gradients is based on the fact that between the Tropics of Cancer and Capricorn where solar insolation is the highest, about 90 percent of the Earth's surface is water. Surface water in this region represents an almost unlimited heat reservoir with areas having a constant temperature of 70°F-80°F, while water at depths of 2,000 feet and below represents an almost infinite heat sink of 35°F-45°F. (31) This system is maintained by both solar insolation at the central latitudes and by melting polar ice caps at the higher latitudes, and the convection resulting from incoming solar energy powers the ocean currents. This temperature gradient can be utilized to generate electricity in a conventional heat engine.

The amount of energy available from exploitation of these thermal gradients is many times the present world demand for electricity. For example, it has been estimated that the ultimate resource of ocean thermal power in the Gulf of Mexico alone is close to 700,000 megawatts. The present

generating capacity of the United States is approximately 500,000 megawatts.(32) Although the potential is tremendous, the energy actually retrievable depends on several factors, including conversion efficiencies, energy transmission solutions, and the depth from which cold water must be extracted. In addition, there are several important environmental questions poised by development of this resource which remain unanswered.

While in some of the demonstrations of the ocean thermal concept sea-water has been used as a working fluid, researchers at the University of Oklahoma feel that:(33)

The economic development of ocean thermal power plants requires the use of a secondary fluid which will boil at about 68°F. In operation, the working fluid would be heated and evaporated by the warm surface water in large heat exchangers. The vapor would then be expanded through turbines to produce electricity and finally condensed to the liquid state in heat exchangers cooled by the deep ocean water.

The potential efficiency of such a power plant has been estimated by several researchers, and is quite low, about 2 percent. Heat exchanger design is considered to be the critical technological obstacle. Within the boundaries of these small temperature differences, heat exchange between ocean water and working fluids must be accomplished with the least possible temperature change. For this, high capacity heat exchangers with large surface areas and very

thin walls are needed, and both the evaporator and condenser heat exchangers must be able to function efficiently over time in a corrosive environment. These units are a considerable factor in the high capital costs of the ocean thermal concept, and are a major area of present research.(34)

The Gulf Stream, off the eastern coast of the United States, is an attractive potential site for ocean thermal power development. Von Hippel has stated that:(35)

This is because the useful energy flowing through a cross-sectional area (in the Gulf Stream) is concentrated by a factor of 1,000 relative to that of the average solar insolation on land, even with the extracted heat limited to what is available with a 1°F temperature drop in the warm surface water passing over the heat exchanger.

It is important, though, to study the effects of a large-scale development of thermal gradients in the Gulf Stream. For example, if too much energy were extracted from this current, severe climatic changes could occur in Western Europe. While this would be unlikely until a very high level of exploitation was reached (Von Hippel has estimated that the present electrical consumption of the United States could be met with a drop of only 0.5°F), it is important to have some idea of the side effects of large scale energy extraction from systems in homeostasis.(36)

The problem of energy transmission represents a potentially serious constraint on the development of ocean thermal

power systems. Although direct electrical transmission may be possible for installations located near the coastline "the difficulties of long distance underwater transmission of the generated electricity would tend to discourage utility interest."(37) One potential solution might be to have energy intensive industries locate near the sites of ocean thermal plants, in much the same way as aluminum plants sought to locate near the lower power cost hydroelectric plants. If the power were relatively inexpensive to produce, a more desirable answer might be found in the conversion of electricity to forms better suited to transportation, such as hydrogen or methanol. Hydrogen could be produced by electrolysis and shipped in liquid form to any location for use in fuel cells, or it could be combined in situ with carbon dioxide to form methanol, a safe, storable liquid fuel which can be used in place of conventional fuels.

It may be that potentially beneficial side effects of the ocean thermal concept will help to accelerate development of this technology. For example, ocean thermal plants would produce fresh water and some of the power could be used to produce nitrogen for use in fertilizers. Many proponents acclaim that the ocean thermal process will result in the transfer of carbon and phosphates from the ocean depths as the cold water was drawn up to the surface.

This could result in the development of nutrient-rich upwelling regions such as exist naturally off the Peruvian coast and help improve fishing.(38) Additionally, the electrolytic separation of water could be used as a source of deuterium atoms which exist naturally in sea water, for use in fusion reactors if this technology is eventually developed.

In the literature, reports on the outlook for ocean thermal power plants range from "encouraging" to "enthusiastic", and the general feeling is that this technology may make an important contribution to our future energy supply. The "when" will be largely determined by the willingness of the government to help supply the funding for pilot plant and commercial prototype designs so that a working knowledge of this technology can be achieved and commercially marketable installations developed. Estimates for the capital costs of ocean thermal plants range from \$540-\$800 per kilowatt installed capacity, which compares favorably with estimates for current construction costs for nuclear plants.(39) It is believed that the competitive position of ocean thermal plants will improve in comparison with conventional systems as the fuel costs for these plants continue to rise.

Photovoltaic Power Systems

The development of solar energy in photovoltaic power systems depends on the direct utilization of light energy to produce electricity rather than heat. It is based on the "photoelectric effect" which was first reported in 1887 by Hertz, and later explained by Einstein in 1905.(40) The first photovoltaic cells which employed this effect were in solid state semiconductors produced by Bell Laboratories in 1954 as an outgrowth of transistor development. Their chief utilization to date has been limited to power generation for the space program, and for remote communications systems. Due to their high cost, applications have been on a limited basis, and in spite of recent developments in production technology they are still too expensive for widespread use in the generation of electric power. Experts are generally optimistic, though, that costs will continue to fall, and many feel that one of the largest future markets in solar energy will be through the use of these cells.(41)

The function of photovoltaic cells, or "barrier-layer cells", has been succinctly described by Daniels:(42)

(They) involve a P-N junction in a semiconductor between a positive layer which contains movable positive charges or "holes" and an N-layer which contains movable negative electrons. When light of sufficient energy enters the crystal, electrons are released and they flow to an electrode and through a wire to the other electrode where they combine with the positive holes. A barrier at the P-N junction prevents the instant recombination

of electrons and positive holes and causes the electrons to go through the wire, generating useful electricity.

No material is consumed in this generation of electricity, and the cell can operate indefinitely.

The best results to date have been obtained with semiconductor diodes made of high purity crystal silicon, which have reported operational efficiencies of 17-18 percent. Laboratory tests have shown that efficiencies as high as 22 percent are attainable. In addition, several other materials have been used in the production of solar cells; some represent attractive alternatives (see Table 1). (43)

TABLE 1

Solar Cell Materials and Theoretical Efficiencies

<u>Solar Cell Material</u>	<u>% Efficiency</u>
Gallium Arsenide	24
Cadmium Telluride	24
Indium Phosphide	23
Silicon	22
Cadmium Sulfide	22

Of particular interest are cadmium sulfide crystals, because they appear to be well suited to mass production technologies where significant cost reductions would offset lower operating efficiencies. In spite of this potential, though, the cadmium sulfide cells so far produced have been unable to compete with the more expensive silicon cells because they do not hold up well over time, and reduced efficiencies are characteristic, while silicon cells are highly reliable over time.

The potential of photovoltaic power systems has been plagued by the high costs characteristic with production. Until the present, the fabrication of silicon cells (the cells with the longest production history) has been an expensive, labor intensive process, where crystals have been grown and then cut and prepared on a very small scale. New production technologies are under study by a joint venture of Mobil Oil and Tyco Industries, whereby long ribbons (up to 80 feet) of crystal silicon can be grown and solar cells produced on a much larger scale. Although it will take several years to fully develop the production process, researchers at the Waltham, Massachusetts plant are optimistic and hope to achieve a 50 or 100-fold reduction in the cost of the silicon cells.(44) This would be a major step toward the widespread utilization of this technology.

Several different schemes exist for the utilization of photovoltaic cells to generate power, ranging from home use to large electrical generating plants, located either on the surface of the Earth or in near-Earth space. At the household level photovoltaic cells could be combined with solar collectors in a system which would provide both space heating and electrical needs of the building. The possibilities of this concept will be more fully developed in a later chapter.

Large-scale power production is an attractive application of the photovoltaic technology, although any utilization would be dependent on considerable cost reductions in the cost of the cells. Ralph, (45) and others, have proposed the construction of large photovoltaic arrays on the ground in areas of high insolation, where electricity could be generated, converted to AC, and directly added to the transmission grid. The present economics of these plants are prohibitive, although the combination of rapidly improving technology and escalating energy costs may make such an alternative competitive by 1990.

P.E. Glaser's plan for a satellite solar power station is well known and may become a viable energy alternative by the dawn of the next century. In this concept, a satellite at an altitude of 22,000 miles in a geosynchronous orbit parallel to the Earth's equatorial plane would employ photovoltaic cells to collect solar energy and transmit this energy to a ground receiving station in a microwave beam. To avoid power loss when the satellite passes through the Earth's shadow, Glaser proposes that a second satellite at the same altitude, but 21° out of phase and 7,900 miles apart from the first, be set up so that continual power transmission to Earth would be possible.(46) Glaser's design calls for a circular solar collector with a diameter of about 3.3 miles,

with a surface area of about 8.7 square miles. The collector would intercept solar radiation and transmit it to a transmitting antenna by means of a long tether. Thus, the pointing accuracy of the collector itself would be noncritical. Amplifiers would convert the electricity to microwave radiation and this radiation would be transmitted to Earth. Glaser has proposed the use of a 10 cm microwave wavelength to minimize the possibilities of atmospheric absorption. The transmitting dish antenna corresponding to this desired wavelength would be about 2 Km in diameter and would irradiate an area of about 3 Km in diameter on the Earth where the microwave radiation would be reconverted to electricity using highly efficient solid state rectifiers to absorb the microwave energy for use in a power grid. The directional accuracy of the transmitting antenna would have to be very high, but this is technologically feasible. Energy storage would not be a problem with this concept, as at least one of the satellites would have an unobstructed view of the sun, except possibly for brief periods of solar eclipse. The energy potential of such a system is tremendous, and the first such stations could be designed to deliver 10,000 megawatts to Earth.

In spite of this potential, the problems in developing such a power source are at least as great as the potential benefits. To begin with, the weight and costs of solar cells would have to be drastically reduced and the efficiencies increased before such an alternative could become economic. Also, there would have to be major developments in the space program which would make it possible to transport and assemble a station of this size in space. For deployment of such a generating system it is estimated that 30 space shuttle vehicles would be needed, with several flights per day.(47) The environmental effects of this level of space travel would have to be carefully evaluated. In addition to noise pollution, rocket fuels dump large amounts of chlorine directly into the stratosphere as hydrochloric acid (estimated at 100 tons per shuttle flight), and this could be considered unacceptable given the concern lately about the effects of chlorine on the ozone layer.(48) Although this chemical pollution might be reduced by the use of hydrogen-oxygen fueled shuttles, the effects of additional water in the upper atmosphere must be studied.

In spite of the discouraging environmental outlook and complicated engineering problems which face this proposal, the primary barrier to development of solar satellite power stations will be the tremendously high cost. Costs were

roughly estimated in 1972 to be about \$20 million per 10,000 megawatt station (\$2,000 per kilowatt) including transportation and ground support. (49) Over 50 percent of this cost is attributable to the solar arrays, which were estimated to cost \$32 per square foot, and incredible reduction from today's costs of \$1,000 - \$8,000 per square foot for space qualified solar arrays. Thus, though the concept is an appealing one, the present economic outlook is very discouraging, and the probability of development of this technology must be considered very low.

Electrical Generation from Wind Power

Among the various technologies for conversion of solar energy into electrical power, the generation of electricity from the wind is perhaps the most attractive alternative for the near future. Proven and well developed technology, combined with favorable economics, may result in a major contribution by wind power to our generating capacity by the year 2000. (50)

It is estimated that at the most general level approximately 2 percent of the solar energy incident on the Earth is converted to wind energy within the atmosphere, (51) and that 30 percent of this wind energy is generated in the lowest 3,280 feet of the atmosphere. (52) The utilization of a portion of this energy is not expected to have any

harmful environmental side-effects, as the lower atmosphere is continually replenished by natural meteorological processes. Within the United States there are several promising locations for wind power development, including the coastal margins along the Atlantic and Pacific Oceans and the Great

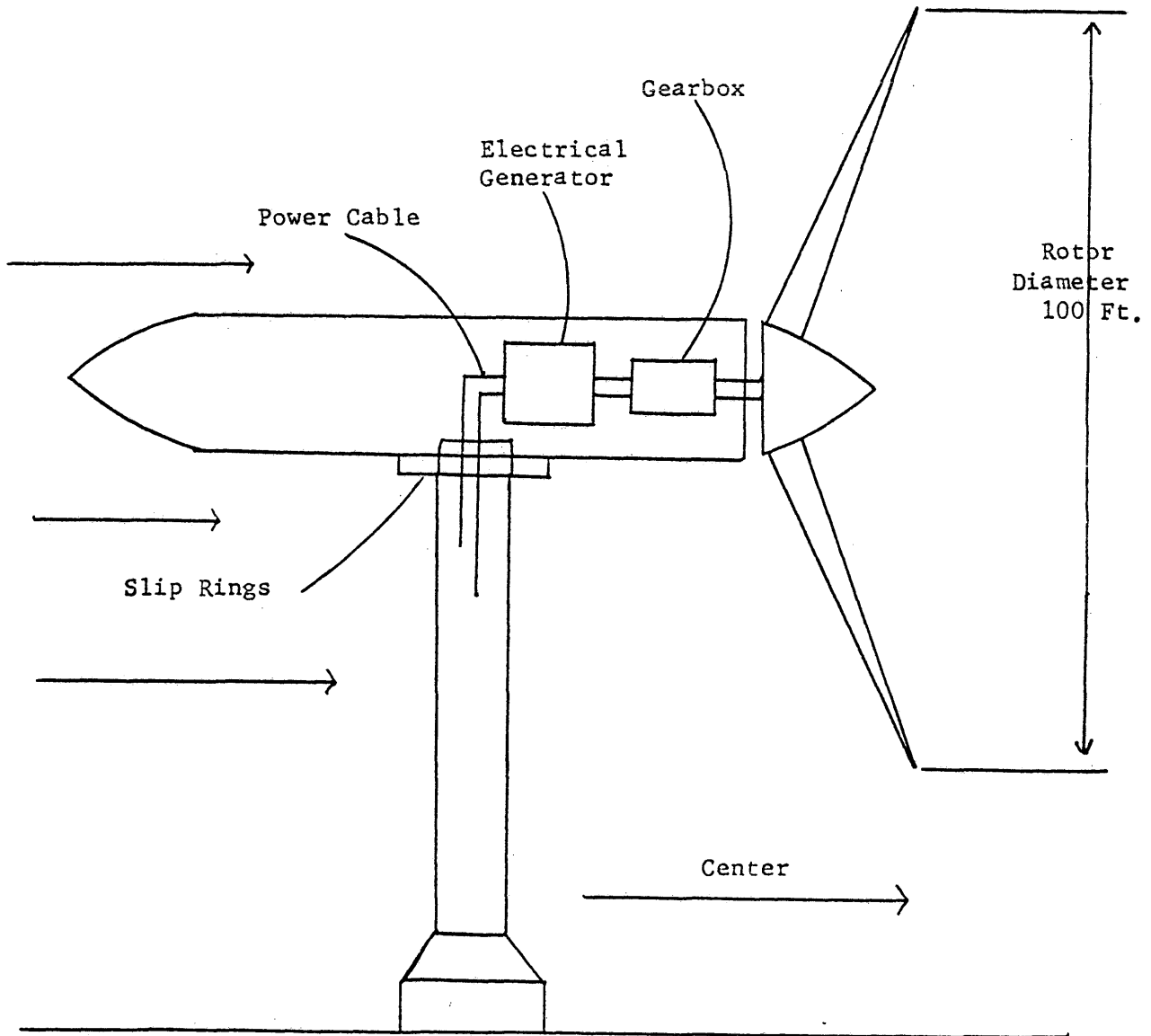

Figure 7: Typical Aeroturbine Design

Plains, stretching from the Dakotas to Texas. Proposals have also been made for harnessing offshore winds. A typical windmill design is shown in Figure 7.

Whereas the use of windpower has traditionally been limited to relatively small-scale operations for pumping water or milling grain, the future potential lies almost exclusively in the generation of electric power, and there are several advantages of wind power used for this purpose. First, in solar thermal systems the greatest energy losses occur when solar energy, in the form of heat, is converted to mechanical energy to drive a turbine. It is therefore desirable to employ a system which can directly utilize the mechanical energy already produced by the sun. The winds are such a source of mechanical energy. Second, the energy associated with the winds is often more concentrated than solar energy incident on the ground. Williams and von Hippel have stated this advantage convincingly. (53)

At a favorable location, a typical wind velocity at a couple of hundred feet above ground level is 20 miles per hour. At this velocity the power through a surface perpendicular to the wind is 45 watts per square foot, or nearly 3 times the average solar insolation on the ground. The high quality of this mechanical energy is demonstrated by the fact that a windmill can convert to electricity about one-third (ideally, $16/27$ or 59 percent) of the energy incident on the area swept out by the propeller. Thus, a wind of 20 miles per hour would yield nine times as much electric power per unit area as a 10 percent efficient solar thermal unit.

ARTHUR LAKES LIBRARY
COLORADO SCHOOL of MINES
GOLDEN, COLORADO 80401

A third important characteristic of windpower is that the power output from the rotor is a direct function of the square of the diameter of the blades and the cube of the wind velocity.(54) This exponential relationship means that the power generated by a wind of 25 miles per hour is almost double that produced by a 20 mile per hour wind, and clearly establishes the need for identifying sites with constantly high wind velocities. Furthermore, this relationship means that the average power produced by such a windmill can be much greater than the power produced by winds of average velocity.(55) Finally, the intermittence of wind power is less critical than solar insolation, which is one of the major limitations of the solar thermal approach. A widespread deployment of wind generators can supply a direct input into a regional power grid as base-load capacity, with the emergency fill-in and peaking capacity supplied by conventional electric power sources. This concept is based on the deployment of aeroturbines over a sufficiently large area so that the wind is certain to be blowing somewhere in the sub-grid at all times. In addition, because of the direct input to the power grid, the need for energy storage is avoided, or at least considerably reduced.

The relative absence of any major environmental effects also contributes to make wind power an attractive technology. Although there will most likely be complaints about the

aesthetics of aeroturbines, much as there already exists for electrical transmission lines, this is not anticipated to be a major obstacle. Also, many of the prime areas for wind development are in areas of relatively sparse population, notably along the Great Plains. While there may be some conflict regarding the restriction of air space around aeroturbines, the design concepts of windmills are a good example of multiple land use, and are perfectly compatible with farming. Moreover, there is no waste heat associated with this means of energy production, a considerable problem in conventional generating plants.

The technological requirements of wind power systems are well developed compared to other solar technologies, and relatively modest by today's standards. Many of the components, especially the electrical generators and transmission equipment, are readily available items. Although the integration of these components into an efficiently operating power facility will require further development and engineering, the primary problems are not in concept and research, but rather in successful demonstration of design.

One potential problem in wind power generation is the effect of vibrations caused by variable wind speeds on the component parts of the windmill which could lead to a high

rate of equipment failure. Although some windmill designs can minimize the potential effect of wind-induced vibrations, this might restrict the choice of sites for wind power development to areas of nearly constant wind velocity.

Another problem frequently mentioned in the literature is that due to fluctuations in wind velocity, which affect rotor revolutions per minute, which, in turn, affect output frequency, there may be some problem in adapting aeroturbines to power grids which operate at a constant frequency alternating current (60 Hertz). While it might be possible to alter some of our demand for electricity to direct current and avoid the problem, this is a sub-optimal solution. Also suggested has been the adoption of constant-speed drives to the rotor assembly, but as this solution impairs the maximum possible efficiency, it is also sub-optimal. A solution has been presented by researchers at Oklahoma State University, who have developed a field-modulated generator which provides an output frequency that is independent of the shaft speed of the rotor.(57) Such a generator may increase the initial investment in the power station, but it is hoped that this cost would be scaled down with larger-scale production.

In general, it is believed that wind power systems will benefit greatly from economies of scale. Von Hippel

has stated:(58) "the relatively small unit sizes of windmills, and the corresponding large numbers needed to produce appreciable generating capacity make windmills well suited to cost cutting mass production technologies," It is believed that this adaptability to large-scale production will accelerate the development of wind power and make its utilization one of the earliest widespread applications of solar energy.

Economics, the critical test for acceptability of a new technology, also appear to be favorable for wind power. A study prepared at the University of Oklahoma in 1975 estimated that once prototype systems had been sufficiently well developed, windpower systems could be built for about \$150-\$200 (1974 equivalent dollars) per installed kilowatt.(59) This compares with estimated costs of \$200-\$350 for conventional fossil fuel plants, and \$500 for nuclear plants. To achieve the same output as the other generating alternatives, with their higher load capacity, the installed capacity of the system would have to be three times as great, with increased capital investment assumed to be roughly in proportion. It was further estimated that:(60)

Assuming a 25-year payback of capital along with a 25 percent load factor, 10 percent interest on debt, no provisions for energy storage, and a conservative allowance for operating costs, a typical installation will produce electricity at an average of 2.0 to 2.5 cents per kilowatt hour.

Although the first wind power generating systems will certainly cost more than this, these figures reveal that the economics are at least "in the right ballpark". They do support a move to develop prototype installations which will evaluate the accuracy of these estimates and encourage more detailed economic analyses. It does appear, though, that as prices for conventional fuels continue their upward trend, raising the operating costs of power generation, the position of wind power will become an increasingly competitive economic alternative. An estimation for the potential contribution of wind power to domestic electrical supply made by a research team at the University of Maryland supports this conclusion. They estimate that an annual output of 5.1 quadrillion Btu from wind power was possible by the year 2000. (62)

Bioconversion to Fuels

A great deal of our present concern about energy is attributable to our shrinking reserves of rapidly exploitable conventional oil and natural gas in the face of a tremendous commitment and dependence on these forms of energy. One means of escaping this potential trap, and preparing for the future, will be in the exploitation of solar energy for the production and utilization of plant biomass (organic material) and "the conversion of this biomass to a variety

of clean fuel products and other useful, clean energy forms."

(63) By developing these technologies it is hoped that a considerable contribution could be made to our current demand for liquid and gaseous fuels. In recognizing this potential, the E.R.D.A. Task Force on Solar Energy has set a goal of 15 quadrillion Btus (15×10^{15} Btu) of energy produced by various bioconversion processes by the year 2000.(64) This goal is based on an accelerated development plan aided by government subsidation in the early years of research, development, and "Proof of Concept" experiments. But it is hoped that, once the concept has been commercially demonstrated, government influence could be minimized.

The production of fuels by conversion of biomass represents "the only renewable method of fuel production known", and it is characterized by a wide diversity of products, many different conversion technologies, and a wide disparity in the degree of development of these technologies.(65) Some of the projects, like combustion, already exist in commercial use, while others, like enzyme reduction, are in the early phases of research and development. Products of bioconversion include methane, alcohol, synthetic natural gas, heat, steam, organic compounds, hydrogen, and potentially useful residues.

The methods for bioconversion to fuels (BCF) can be roughly divided into two basic applications, and Figure 8 summarizes the energy systems which they describe. The first technology involves the "collection and utilization of organic waste materials as a source of energy fuels", while the second involves, "the production and utilization of crops (including trees) as a source of energy." (66) Waste utilization technology is more fully developed at present, and this technology may make a contribution to our fuel supply by the mid-1980's, while energy farming may not become widely developed until the mid-1990's.

Although bioconversion of organic materials represents an attractive utilization of solar insolation for the production of energy, there are several constraints which may inhibit its widespread acceptance. Land use conflicts may exert a strong limitation on BCF development. The proposed concepts for large-scale energy farms producing either fast growing trees, or land or water crops in shallow ponds, may eventually be competing for land which could be producing ponds, may eventually be competing for land which could be producing food. If a decision is to be made as to how to utilize an area of land, for either energy or food production, the higher economic value of food will lead to this use of the land. Even though many BCF proposals suggest the use

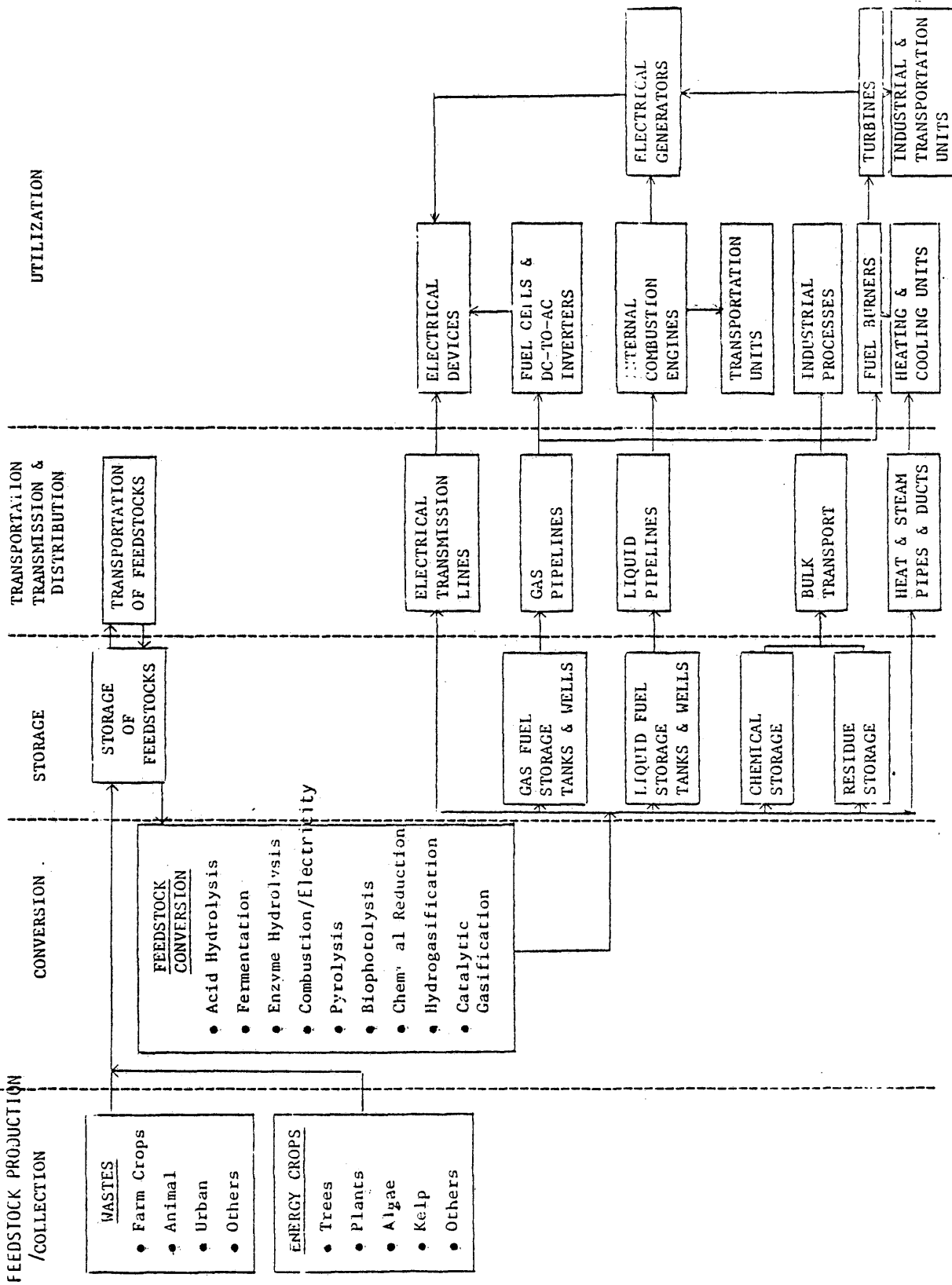

Figure 8: Bioconversion of Fuels -- Energy Systems

of the land. Even though many BCF proposals suggest the use of locations in the Southwest, where solar insolation is high and water could be transported in or produced in solar stills, if the demand for food were sufficiently great, these areas would be forced to switch over to food production. In addition, energy farms may also find themselves competing with food producers for scarce fertilizer resources, with the food producers having the preferential advantage.

Another factor which may undermine the position of BCF plants is the availability of feedstocks. Many conversion plants will be dependent on a high degree of urban waste, and wide-spread move into a recycling economy could place severe limitations on the raw materials needed for bioconversion. Although long-term contracts with municipalities would seem to be one solution, it is important to encourage the economics of multiple use. While the possible competitive economics of these two industries merits further investigation, there is still a definite need for long-term contracts to be established between BCF plants and municipalities, for only with some guaranteed supply of feedstocks will financial institutions be willing to underwrite these projects. High transportation costs represent another factor which may detract from the economic attractiveness of bioconversion. These costs are incurred in at least two stages of production,

feedstock collection and fuel transportation to market, and represent a major part of the cost per Btu of energy produced. This percentage must be reduced before BCF can become an economic reality.

On the positive side, environmental aspects represent one of the major attractions to bioconversion. BCF plants would supply a market for urban solid wastes, which are a nuisance and seldom disposed of in a satisfactory fashion. Furthermore, the technologies of bioconversion have a minimal environmental effect, and the fuels produced are much lower in pollutant emissions than the conventional fuels which they can replace. Finally, a significant development of energy farming could result in significant amounts of oxygen produced and returned to the atmosphere through plant photosynthesis, reversing our efforts to diminish the oxygen level with the destruction of large parts of our ecosystem as an outgrowth of population increase and urban expansion.

Support for bioconversion technologies is broadly based, with a substantial commitment expressed by private institutions and a willingness in E.R.D.A. to proceed with development strategies. Initial funding will come from both private and public sectors, although a strong governmental commitment will be necessary to establish the "Proof of Concept". Pilot plant operations have already been initiated for an

urban waste conversion to methane plant, and this and other small-scale development projects will help to firmly establish the economic potential of this alternative. Once these data are known it will be possible to more accurately predict the contribution which BCF systems can make, and to what extent government will be required to insure active participation from private industry. With bioconversion, as with the other solar technologies we have discussed, it is important to remember that the changing economics of conventional energy sources will have an important effect on the timing and extent to which this technology will have a significant, if any, impact on energy supply and demand within the United States.

Energy Storage Systems

Because solar radiation is by nature highly variable, affected by haze and clouds, as well as the fact of its availability for only half the day, some sort of energy storage system is necessary for all of the technologies which depend on direct insolation. This is especially important for the large-scale production of large-scale production of solar energy where economics favor the alternatives with the highest load capacity factor. In some cases, energy can be stored directly as heat or electricity, while in other instances it is more desirable to change the form of

the energy into a more easily stored or transported state, suitable for use at any time.

Several large-scale energy storage systems have been demonstrated, while others are still in the development stages. The Pump-storage Power Plant is one example of a well proven technology for the storage of mechanical energy, and could be applied to a solar power plant. During the day, when solar insolation is at its peak and electrical demand is not, excess power can be used to pump water uphill to a storage reservoir. In the evenings, when power demand is usually very high and solar insolation is very low or unavailable, the water is allowed to run down the hillside to power an electric generator. This cycle repeats itself each day, and a reservoir of sufficient capacity to provide energy for periods of bad weather is needed. The pump-storage concept has been used in many locations within the United States, and no new technology would be needed for the application of this concept to a solar power installation.

Storage batteries have an important potential use in the storage of electrical power from solar energy, although their use is on a somewhat smaller scale. The conventional lead-sulfuric acid storage battery, found in almost every automobile in the world, is an efficient and highly developed storage system, which is easily adaptable to solar energy

storage. For home use a solar collector could generate electricity during the day which could charge in parallel a group of storage batteries. In the evening these batteries could be coupled in series to supply power for cooking and home lighting. For electrical storage on a larger scale it has been proposed that a solar electrical generating plant could produce electricity for a central power transmission grid during the day, supplying the bulk of demand, while conventional plants operated at minimal output, conserving their fuel.(67) After the sun has gone down the conventional plants would increase production levels to normal and supply the power demanded.

Fuel Cells, in which chemical reactions are converted into electricity, are an attractive alternative for energy storage. In these electrochemical cells "fresh reacting chemicals are fed into the cell continuously as the original material is used. The structure of the cell and the electrodes remain unchanged while more chemicals are added."(68) A very high efficiency is possible in fuel cells, as between 50 and 70 percent of the chemical energy can be converted to electricity. Furthermore, the cells are of relatively simple construction, have no moving parts, and are relatively inexpensive.(69)

These positive attributes have led to a great deal of enthusiasm and research on fuel cells, but several factors have limited their widespread utilization. First among these drawbacks is the comparatively short life characteristic of most fuel cells, which raises the operating cost above other alternatives. Also, the costs are high because most of the fuel cells designed chemically combine gases which require the use of catalytic electrodes surfaces which are made from the noble metals. These electrodes often become clogged and require frequent replacement. It is generally believed that these problems will be solved with continued research, and that the costs of energy storage using fuel cells will become an increasingly competitive relative of storage batteries.

Energy storage systems which can convert solar energy into forms more suitable to long distance transmission may provide an important contribution to the development of this energy source. The production of hydrogen using solar generated power is an attractive possibility. Hydrogen fuel can be transported over long distances by natural gas pipelines or shipped by truck or ship in liquid form and in situ storage is possible in both liquid and gaseous forms using large tanks (economics favor storage as a gas because of the need for insulated tanks for liquid storage of hydrogen). Hydrogen fuel can also be utilized in many ways.

ARTHUR LAKES LIBRARY
COLORADO SCHOOL of MINES
GOLDEN, COLORADO 80401

Although it can be employed as fuel in internal combustion engines, hydrogen is most efficiently used in fuel cells, where it chemically reacts with oxygen to produce water and electricity. (70)

Hydrogen can also be used as a fuel to burn with air for heating boilers for steam engines or turbines; or it might be used without a boiler by burning directly with air to provide high temperature steam within a turbine.

Hydrogen can be combined with carbon dioxide to produce methanol, an easily transportable, stable fuel which can be substituted for conventional fuels. While the extraction of carbon dioxide from the atmosphere is relatively expensive (because of the low CO₂ density), methanol production may provide a use for the carbon dioxide produced at ocean thermal power plants, as previously mentioned.

Hydrogen production has generally been accomplished by electrolysis, in which electrical energy is used to evolve hydrogen and oxygen gases from water. The technology is proven for this process, the capital costs for the electrolytic cells are low, and efficiencies of up to 70 percent can be achieved. Furthermore, the electricity needed for the electrolytic reaction can be produced by most solar technologies, including photovoltaics, solar thermal, ocean thermal, and wind power systems. Because of the loss in efficiency in converting thermal energy to electrical energy, it would seem

that the electrolytic production of hydrogen could best be accomplished by wind and photovoltaic systems, which produce electricity directly. Due to the low efficiencies (10 percent) and very high cost of photovoltaic arrays at this time, wind systems would be favored on an economic basis.

Hydrogen production could, however, be produced by solar thermal power employing a process of thermochemical water decomposition. This process has been described by Eisenstadt and Cox, (71) and involves a series of thermochemical reactions which can occur at temperatures attainable by existing concentrating collectors resulting in the production of hydrogen gas. One widely publicized process, the "Mark 1" is presented here with the reactions and the temperatures at which they occur: (72)

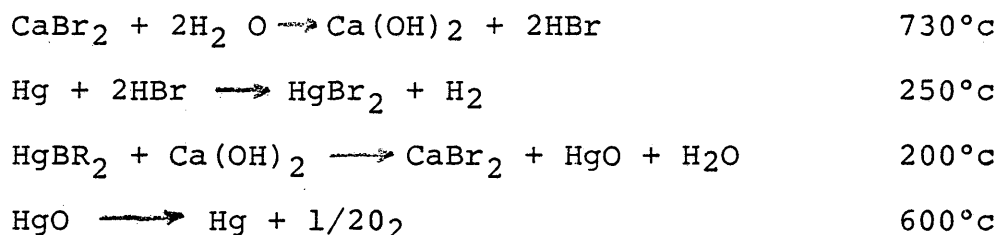

In this process all of the reactants are completely recycled with the exception of the dissolution of water and the overall process efficiency is claimed to be between 40 and 60 percent. Eisenstadt and Cox claim that these temperatures are well within the reach of concentration solar collectors, and the results of their economic analysis demonstrate that such a

thermochemical process is a more economical method of hydrogen production than either a photovoltaic or solar thermal electrolytic process.(73) It is important to mention, though, that the thermochemical dissolution of water for hydrogen production is still in the early stages of development. Until this technology is proven, hydrogen production from solar energy will most likely be through an electrolysis process.

Within ocean thermal power plants it would seem that the electrolytic production of hydrogen would be favored because the high temperatures needed for a Mark 1 type of process do not exist. It is important, however, to have a storage capability for an ocean thermal plant, especially if it is located far offshore, where electrical transmission is expensive. Under these circumstances, the electrolytic evolution of hydrogen for combination with carbon dioxide to synthesize methanol would probably be the favored storage medium for an ocean thermal installation.

Attractive technologies exist for the storage of solar energy, but they are generally very expensive. This has been one of the primary reasons for the slow development of the solar resource. In spite of the great enthusiasm and high expectations for the potential of solar energy, the diseconomies of required storage still exist while our conventional

fuels need none. Although progress on storage systems has been made, it is apparent that a widespread development of solar technologies is critically dependent on the reduction of energy storage costs, and that the successful solution of this problem would radically improve the competitive position of solar energy.

Integrated Systems

Several different concepts have been examined above for the generation of large-scale power from solar energy, and an attempt has been made to focus on some of the inherent problems as well as to point out the potential advantages. It has also been proposed in the literature that one or more of these solar technologies be combined as component parts of a larger, centralized solar power plant.(74) Although it would be difficult to find a location where solar insolation, wind power, an ocean thermal gradient, and bio-conversion facilities could all be exploited to a high degree, there would be several benefits which could accrue to such an installation (southern Florida might be such a location). Energy transmission costs and storage requirements could be reduced, and storage space could be shared among the different energy producers, especially in the case of hydrogen fuel. A multi-component power park would also be able to operate at a higher overall load factor

than could any one of the individual components because it would be unlikely that several of the components would be down at any one time. In this way power production could remain at high levels, with routine maintenance set up on a staggered basis.

Researchers at Oklahoma State University have proposed a design for a multi-staged solar power plant, and its operation is blocked out in Figure 9.(75) This design makes use of wind, solar thermal, and bioconversion power production, and delivers energy as AC household current electricity, hydrogen fuel, conventional hydrocarbon fuels (methane, methanol, etc.), and steam, which can be used for heating and cooling, as well as in industrial applications. The AC electric power would become direct input into a regional transmission grid, and during periods of reduced demand the surplus power would be storable hydrogen fuel in a high-pressure, high-efficiency electrolysis unit. Hydrogen fuel would be transported by pipeline to other locations, and also burned in an aphodid burner to produce steam at the power plant. A field modulated generator would be utilized to produce AC current from the aeroturbines and from the solar thermal steam turbines. A preliminary economic analysis by the team at O.S.U. indicates that such a system is already competitive with conventional power production, and it is their feeling that construction could be immediately begun.(76)

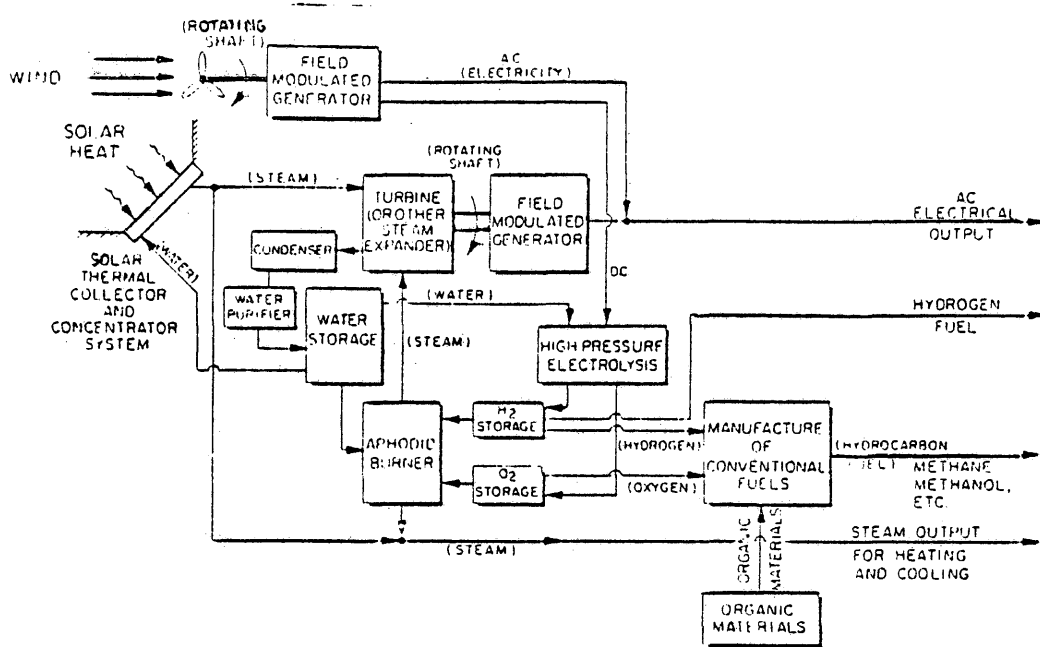

Figure 9: Diagram of a Solar Energy System for the Immediate Future

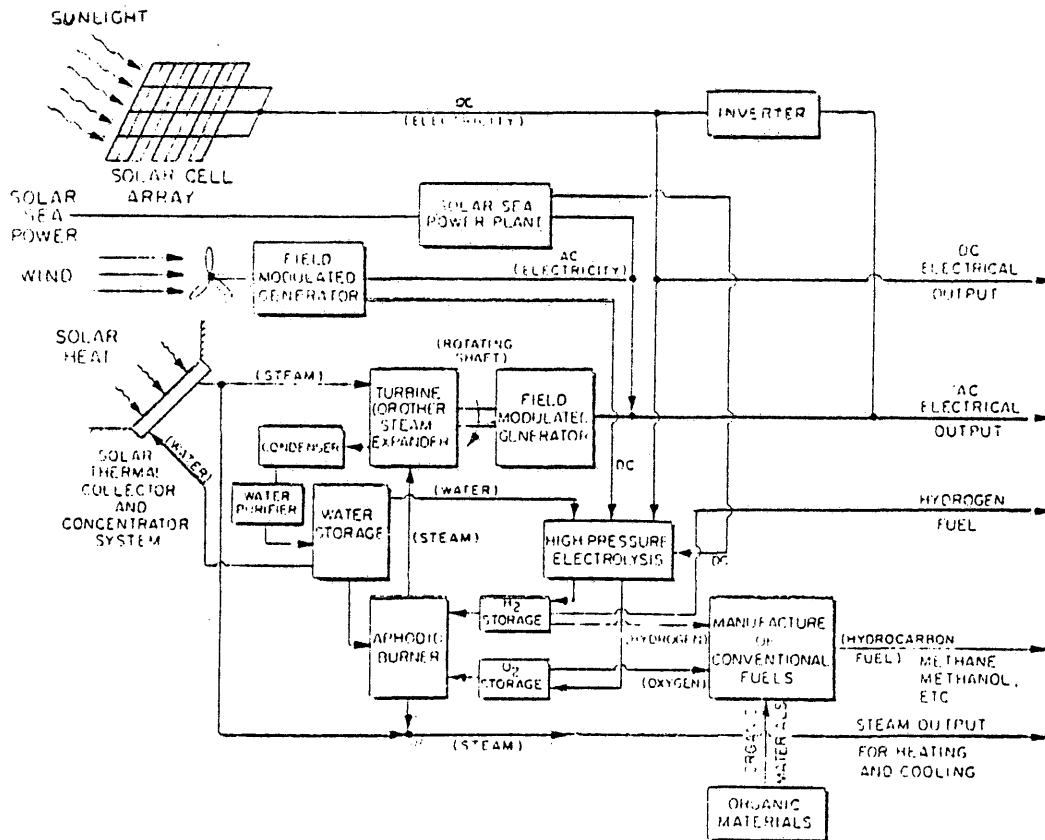

Figure 10: Diagram of a Solar Energy Systems for the Long-term Future

A system designed for the long term future was also presented, and is diagrammed in Figure 10.(77) Basically an expansion of the smaller system, Figure 10 shows that a photovoltaic array and an ocean thermal installation have been added to the power plant. The addition of these components would be dependent on capital cost reductions and further technological refinements. The authors are optimistic that these problems could be solved and construction of the components begun by the mid-1980's.

In the opinion of this author, the timetable presented by the O.S.U. researchers is somewhat too optimistic, but the potential of a multi-staged power plant is indeed great. Different technologies for solar power generation will be developed as they become economical alternatives, but the incorporation of several technologies into one power park will most likely follow the successful demonstration of each technology on an individual basis. It is important, however, to recognize that a solution to our current energy dilemma will not come in any one form. If solar technologies are to make a contribution, it will come from all the technologies and concepts discussed, and even then represent only a partial solution. Because there is a sound economic basis for the integration of different technologies in a large-scale power facility, installations of this nature will have an important role in supplying our future energy needs.

Small-Scale Utilization of Solar Energy

In addition to the design concepts presented above for the production of solar energy on a large scale, a vast number of smaller-scale applications exist. Within the United States power consumption is at such high levels that a major contribution of solar energy would necessarily be geared to large-scale energy production. This is not true for all countries, and it may be that the first uses for solar technologies on a wide level will come from developing countries, with high insolation and little capital to invest in major energy production facilities. In such countries the need for "intermediate technologies" is often more critical than massive technological importation.

The industrialization of the western world was made possible largely because of abundant, cheap fuel, and while the fuel is no longer inexpensive, the industrialized nations have developed the economic infrastructure which enables them to explore the additional energy sources or to trade for foreign supplies. Because industrial development is dependent on energy utilization, many Third-world nations are crippling their emerging economies with the high cost of energy in an attempt to become sufficiently industrialized to reduce their balance of payments deficits. In these countries it is not just the high cost of fuel which is devastating, but the cost of transporting energy to rural

areas is also expensive. Whether the energy is transported as diesel fuel or electricity to run an irrigation pump, some transportation facility, serviceable roads, or a transmission grid, must be constructed.

The utilization of solar technologies within developing countries may make an important contribution toward solving the problem of ultra-high energy costs, especially in rural areas. In countries with a high degree of insolation, solar energy can be used to do the work that conventional fuels have done, often with an economic advantage. Solar stills can provide fresh water, a real problem in many rural areas. Solar cooking units can be utilized instead of animal dung, and this waste used as fertilizer. Refrigeration units powered by solar insolation can supply food storage facilities and prevent food waste and sickness, which often results from eating spoiled food. Solar energy can also be used to run small heat engines for use in agricultural irrigation, greatly improving the manpowered systems used in much of the world, and replacing diesel units which depend on imported fuel. Finally, generators can be powered by the sun to produce electricity for home use.

In general, these solar technologies are well developed and are easy to operate. Although their cost is usually somewhat higher, their operating costs are extremely low,

and government support could result in a widespread use of these devices. Such a utilization of the intermediate technologies of solar energy could satisfy energy dependent household needs, and would also have a positive economic effect on the country in reduced fuel imports. Developing countries, such as India and Pakistan, have expressed the need for a wide-spread use of solar technologies for many years, and it now seems that with the rising costs of imported fuels the solar alternative is becoming economically attractive. There is, then, a considerable market for the intermediate technological applications of solar energy within developing nations, and production facilities are developing to meet this need.

CHAPTER 4. SOLAR ENERGY TECHNOLOGIES
FOR THE HEATING AND COOLING OF BUILDINGS

Within the United States perhaps the greatest potential for solar energy exists in supplying the heating, cooling, and hot water needs of residential and commercial buildings. This sector currently consumes 25 percent of all energy used by Americans, and the application of solar technologies to these requirements could result in a substantial saving of conventional fuel sources. Solar energy is well suited to this task because the temperature demands are not great, generally between 90° and 200°F. Considerable research has already been done on these applications and the principles and requirements are well understood.

Whereas in the past solar technologies for the heating and cooling of buildings (HCB) has been uneconomical because of lower cost, conventional fuels, this is rapidly changing. As the prices of fuel oil, natural gas, and resistance heating have radically increased in the past few years, the competitive position of solar alternative has dramatically improved. Duffie has stated that: (78)

In areas where new natural gas connections are no longer available, where oil is not distributed, and where electrical resistance heating is the only alternative among conventional sources, solar heating is economically attractive.

While at the present, the competitive position of solar technologies for HCB is limited to specific locations and situations, it is clear that as conventional fuels continue to increase in price the economic benefits of solar power will also increase. Furthermore, the economic attractiveness of solar alternatives in HCB is creating a growing demand for solar products, and this will be satisfied by a newly developing industry. As this industry grows and gains production experience, the costs of solar equipment are expected to drop, further increasing the economic competitiveness of solar alternatives with conventional technologies. Finally, as well as providing a means for the conservation of fossil fuels, this new industry will supply a positive impact on the national economy as jobs are created and physical plants constructed to meet the growing demand for solar products and services. Indeed, by 1985, it has been estimated by Arthur D. Little & Co. that the annual market for solar climate control systems could reach \$1.3 billion.(79) This high potential for solar energy technologies was summarized in a 1972 study by the National Science Foundation and the National Aeronautics and Space Administration.(80)

There is no doubt that among all the possible uses for solar energy, residential heating and cooling has the highest probability of success. There are the least uncertainties both in the technologies and in the economics of the domestic applications. There is, moreover, a very high benefit/cost ratio in that the funds needed for the development of a viable industry will be only a small fraction of the annual fuel savings, or of equipment sales, or of some other measure of benefit to the economy.

Many kinds of systems with widely varying equipment have been proposed for the utilization of solar energy in commercial and residential buildings. Systems are differentiated by both function and the means by which the solar insolation is collected. Solar systems can provide hot water needs or space heating or cooling requirements, or some combination of these. The methods for the collection and utilization of solar energy can be divided into three basic groups: passive, active, and focusing systems. In each of these designs some means of energy storage is included to supply energy needs when the sun is not shining, but storage capacity is expensive to build, and often requires a great deal of space. It is therefore uneconomical to provide storage for very long periods of sunlessness, and a conventional system is used as a back-up to supply energy needs for solar insolation cannot satisfy total energy demand. Load factors for solar systems are typically between 50 and 70 percent and the economic decision made by the consumer

is whether the annual savings in fuel bills justifies the capital investment in a solar system.

Passive Collecting Systems

Passive collecting systems are the simplest method for the utilization of solar energy and can provide some of the heating and cooling requirements of a building. For the passive utilization of the sun's energy, houses are oriented so that they soak up lots of sunlight. This is often done with huge south-facing windows and a protected, windowless north side. A roof ledge extends above the window, which can cut off incoming solar radiation in the summer when cooling is needed, while during the winter sunlight can pour in because of its lower latitude. During the winter day incoming sunlight passes through the windows and warms the interior of the home, and at night heavy curtains are drawn to try to hold as much of the heat as possible. Good heat conservation measures such as having a well insulated and thermally "tight" house are very important in this concept, as in other home uses for solar energy. By combining good thermal insulation with an extensive use of sunlight, a passively heated and cooled home can greatly reduce its fuel consumption without the capital and maintenance costs of a more complicated design.

Many such passive systems have been built, and while the principles are the same the individual applications vary widely, depending on the heating and cooling requirements and building location. Felix Trombe, a leading French authority on solar energy, designed a passively heating house in the 1950's.(81) The Trombe houses had a thick south-facing wall made of masonry, which was faced with glass or some other material which would permit sunlight through to warm the brick, but which inhibited re-radiation of the heat outward. During the night the wall would give up its stored heat to the interior of the house. Heat circulation is provided by natural convection.

Another passive heating and cooling system employs a wall of oil drums filled with water, which absorb heat during the day and give it off to the interior at night. A cover is drawn across the outside wall at night to reduce heat loss to the outside air. The moderating effect of the water can also be used to cool the house. In other passive systems large south-facing windows with two layers of glazing allow sunlight to pass through and warm the house. At night small styrofoam beads are pumped into the cavity between the panes of glass to form a wall of insulation which keeps the heat inside. Still another design, by H.H. Hay, uses a shallow pool of water which covers the roof of the house. During

the day the black painted bottom of the pool (which has a good thermal bond with the roof) absorbs solar radiation and heats the water. At night a sliding cover of insulation is drawn into place over the water, which releases its heat to the living space beneath. This system can be used for cooling by leaving the pool of water uncovered at night.

The major attractiveness of passive systems for heating and cooling lies in the generally low capital and maintenance costs which must be incurred to achieve some degree of independence from conventional fuels. Passive systems are simple in principle and easy to operate, but there are several limitations to the widespread utilization of this design. First of these is the characteristically low thermal efficiency of passive systems. No attempt is made to fully utilize the heat potential of solar radiation and heat exchange occurs relatively slowly. Often there is no means of carefully regulating temperatures, and indoor temperatures may be subject to wide fluctuations, especially on very bright days.

Because the passive approach to solar heating and cooling requires a specific building orientation and certain architectural constraints (such as a large south-facing wall), the market for these systems is almost exclusively limited to new construction, which limits the number of

people it can affect, at least in the near future. The costs of such a system may also be higher than generally believed due to the fact that each system must be custom built to deal with the locational and insolation constraints of each site, as well as the owner's desires. While the need for customizing the systems to the individual site requirements must be dealt with for any solar technology, the cost of this may be greater in a passive system, where the use of solar energy is critically involved with building design.

The unique design characteristics and relatively low efficiencies of passive systems are likely to delay their widespread development, and the eventual market will probably be somewhat limited for systems based solely on passive use of the sun. More active systems will, however, utilize many of the characteristics of passive systems, including good thermal conservation practices and energy conscious building design.

Active Collecting Systems

Active systems for the utilization of solar energy, although more complex and expensive than passive systems, are attractive because they operate at higher temperatures and efficiencies and thus accomplish more work. In general, active systems use solar collectors, usually mounted on the

roofs of buildings, which convert solar radiation into heat energy which is transported by means of a working fluid (normally water or air) to accomplish space and water heating directly. Active systems can also provide heat energy to power air conditioning and refrigeration units, and to run small engines. The temperatures supplied by active systems are well suited to the temperature needs of residential and commercial buildings, and it is generally believed that these systems will represent the first major utilization of solar energy.

Collector Design: Research into active systems for hot water and space heating and cooling has been at a high level since the 1950's, and many different systems have been proposed. Common to all of these systems is the flat-plate collector, which receives light energy and transfers it as thermal energy to a working fluid. While there are many different collector designs, they usually consist of a darkened metal surface, called the absorber plate, which is in thermal contact with the working fluid. The absorber plate is usually in an insulated box, and covered with at least one glazing of glass or plastic. Incoming solar radiation passes through the glass and strikes the darkened absorber plate, converting the shortwave solar radiation to heat, and the long-wave thermal radiation reflected from

the absorber plate is unable to escape through the glass because of the "greenhouse effect". This phenomena is based on one of the properties of glass, which possesses a very high transmittance for shortwave solar radiation (nearly 90 percent) while remaining virtually opaque to longwave radiation. A typical collector for heating water is shown in cross-section in Figure 11.(82) In addition, collectors have been designed which heat water plus an anti-freeze additive such as ethylene glycol, while others use fluorinated hydrocarbons, air, and many other substances. In spite of the variance of designs, Yellot has stated that:(83)

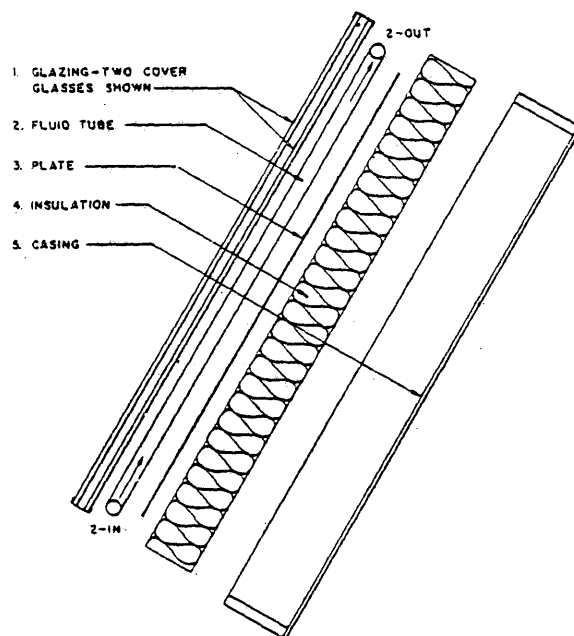

Figure 11: Typical Solar Collector, Cross-section

The major objective has been to collect as much solar radiation as possible, at the highest attainable temperature, for the lowest possible investment in labor and materials. When these goals are attained, the collector should also have an effective life of many years, despite the adverse effects of: the sun's ultraviolet radiation; corrosion or clogging due to acidity, alkalinity, or hardness of the heat transfer fluid; freezing and airbinding in the case of water, or deposition of dust and moisture in the case of air; and breakage of glazing due to thermal expansion, hail, or other causes.

The design and experimentation with different collectors, then, is an attempt to find satisfactory products which meet these criteria and which can be economically manufactured.

One major area of difference is in the glazing materials, which are a primary determinant of collector cost and efficiency. Glass with a low iron content has been widely used to date because it has a high transmittance of shortwave solar radiation with virtually zero transmission for long-wave thermal radiation. Many plastic glazings have been experimented with, but while they have a high transmittance of shortwave radiation, the longwave transmission is also very high at about 40 percent.(84) Although plastics have a real advantage over glass in that they can better withstand the impacts of hail and other stones, few plastics have been able to hold up well over prolonged exposure to ultraviolet radiation. These factors have given the advantage to glass glazings, in spite of their vulnerability.

Glass glazings are typically used in single and double-strength thicknesses, and as many as three layers of glazings have been used. The purpose of these glazings is to admit as much light energy as possible and to minimize the upward heat loss. Additional layers of glazing help to do this, and an airtight seal between layers is desirable so that air leaks can be eliminated. While dust and dirt will accumulate on the glazing, this does not significantly affect transmission, and occasional rain will clean the collectors. A more serious problem is that with clear glass glazings normal reflectance is about 4 percent, and this figure increases with multiple glazings, limiting the usable solar radiation. Although it is possible to significantly reduce this percentage by using antireflective coatings, or by acid-etching the glass, the present costs of these processes are prohibitively high.

Absorber plate design represents another major area of difference between flatplate collectors. The primary function of these designs is for the absorber plate "to absorb as much of the radiation reaching it through the glazing, to lose as little heat as possible upward to the atmosphere and downward through the back of the container, and to transfer the retained heat to the transport fluid."(85) The ability of an absorber plate to accomplish this depends on the

absorbance of the collector surface and the angle of incidence of the solar collector. Flat black enamel paint was long considered to be the best coating for absorber plates, and while new "selective coatings" have higher absorbtivity, black paint is still widely used because of its low cost. In the 1950's Tabor and others (86) developed selective coatings which were characterized by a high degree of short-wave absorbance and low transmittance of longwave radiation which could be applied by electrolytic or chemical processes. In principle these selective surfaces:(87)

...consist of a very thin upper layer which is highly absorbant to shortwave solar radiation but relatively transparant to longwave thermal radiation. The substrate must have a high reflectance and a low emmitance for longwave radiation.

The major criteria for acceptance of a selective surface are cost and durability, and Tabor's electrolytic process has found a large market for collectors manufactured into water heaters in Israel.(88)

Many designs for the construction of absorber plates exist, and these have been summarized in Figure 12.(89) If the collector is designed to heat water it is essential that a good thermal bond exist between the transport fluid and the absorber plate. The problem faced by designers is to construct a system which has good thermal conductance, but which is inexpensive to manufacture. Hence, while the most

efficient designs are those where the water tubes are integral with the absorber plate, these have not succeeded on a widespread level because they require mass production facilities in order to be competitive. This construction is shown in Figure 12(A). Figure 12(B) and (C) shows the addition of water tubes above and below the absorber plate, and while these are easier to construct, this design is not as thermally efficient as (A). Absorber plates are usually constructed from aluminum or steel, both of which will enable good thermal conductance if carefully constructed. (90) The use of galvanized steel layers to form water passages is shown in (E), (F), and (G). Copper, although very expensive, has more superior thermal conductance than either aluminum or steel, and a design showing the spot welding of two copper sheets is shown in (H). H.H. Hay's concept for a passive heating system, discussed above, is shown in (I) and a collector design by Thomason is seen in (J). In Thomason's system water runs in open troughs down the collector where it is warmed. It is collected at the bottom of the collector and flows to an insulated storage tank, where it can then be used for space or water heating.

Different designs for collectors which heat air are shown in (K), (L), (M), and (N). Because of the lower values for heat transfer between the metal absorber plate and air

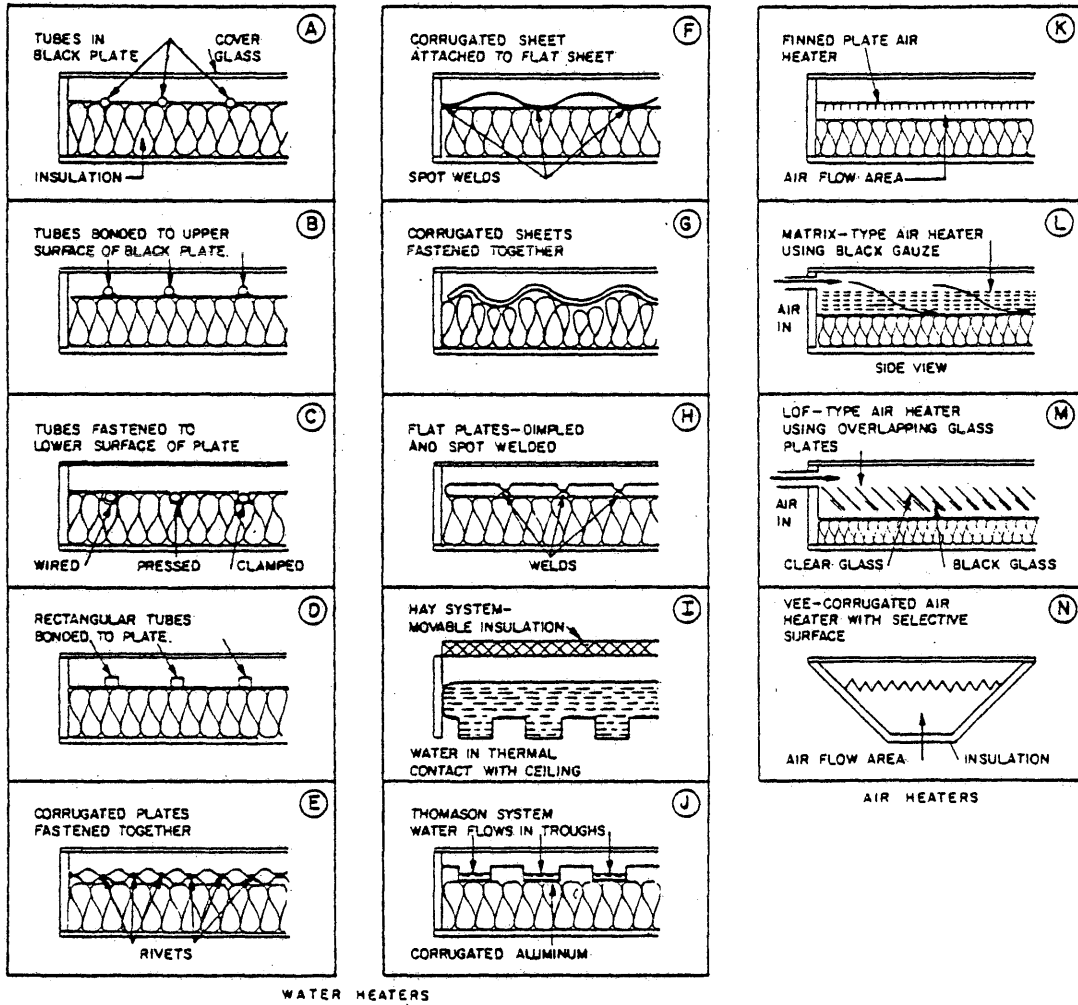

Figure 12: Examples of Solar Water and Air Heaters

it is desirable to have a somewhat larger surface area for the air to come in contact with. Such a design is seen in (K). A matrix material, as in (L), or overlapping glass or aluminum plates (M), have also been suggested as a means of improving this transfer.(91) The air heater design in (N) makes use of selective coatings on a corrugated metal surface. Light striking the selective surface undergoes several reflections with absorption occurring at each surface, with a high degree of heat transfer achieved.(92)

The casings which surround the solar collectors are also subject to important design characteristics. They must be well constructed and able to stand up well to prolonged exposure to sunlight and weather hazards. Several materials have been used, including wood, sheet metal, asbestos cement and plastic. Sheet metal designs are currently the most widely used, although plastic and fiberglass frames are attractive because of their one-piece construction which will be suitable to the mass production economies which are projected to develop. While the amount of insulation needed, and the number of glazing layers used, are a function of the local climate and the temperatures which are desired, it is essential that the solar collector maintain a good seal if it is to function dependably. Finally, wire mesh screens, supported a few inches above the glass, have

ARTHUR LAKES LIBRARY
COLORADO SCHOOL of MINES
GOLDEN, COLORADO 80401

been suggested. Although these screens cut down the amount of incoming solar radiation and additional collector space must be provided to compensate, the extra initial cost may be warranted where frequent hail storms or other occurrences might result in damage to the glazings.

System Efficiency: The Efficiency of a solar collecting system is dependent on several criteria. The design and construction of the collectors is the primary determinant, although there is certainly a trade-off between cost and efficiency. For a well designed and economically feasible collector, which can supply heat in temperature ranges between 150° and 200°F Maddox has described a range of from 40 to 60 percent. (93) This range is widely quoted in the literature. The day to day efficiency of the collector may vary widely, depending on weather conditions including air temperature, degree of cloudiness, humidity, and haze. On a clear day maximum efficiency usually occurs between 11:00 a.m. and 1:00 p.m. As would be expected, certain collectors will function more efficiently in one location than in another.

The angle of collector tilt is an important determinant of efficiency. Because the maximum solar radiation is received on a surface perpendicular to the sun's rays it is desirable to tilt the collector to take advantage of this. In general, collectors are tilted from the horizontal at an angle equal

to the latitude of the building's location. If a collector system is used where the collector angle can be changed, it is desirable to increase the angle during the winter to latitude plus 10 to 20 degrees, and in the summer reduce the angle by 10 to 20 degrees less than the latitude. (94) In this way a collector system can more nearly receive the maximum possible solar radiation.

The rate of fluid flow through the solar collector also has an important effect on efficiency. If the transport fluid moves too rapidly through the collector it will not accumulate sufficient heat to perform its task, and the efficiency of the whole system is reduced. It is desirable, therefore, to enable the fluid to absorb as much heat as possible and still preserve a flow through the system. The flow rate must not be too slow because collector efficiency drops off rapidly if the temperature differential between the collector and the ambient air becomes too great. When this differential is great, there is an increased tendency for the collector to transfer heat to the surrounding air, and efficiency is reduced. Although the use of additional layers of glazing is used to insulate the collector and reduce this differential, a cost is incurred. Because each additional layer of glazing increases the quantity of reflected sunlight, the use of unessential glazing also results in

decreased efficiency. The problem faced by solar energy designers, then, is to design an economical collector system which can operate within these constraints and still achieve a high level of efficiency.

Solar Water Heaters: In spite of this difficult task, many systems for using solar energy have been developed. One of the most successful solar technologies developed has been the use of flat plate collectors to supply water heating. The most widely used design is the thermosyphon water heater, which is shown in Figure 13.(95) In this design an insulated storage tank is located at least two feet above the top of the collector. Cold water leaves the tank and goes to the bottom of the collector through a downcomer. An insulated pipe connects at the top of the collector and carries hot water up a riser to an inlet tap about two-thirds the way up the storage tank. Hot water is drawn off the top of the tank for home use. In this closed system, cold water is heated in the collector by the sun and "the warmed water flows slowly upward through the tubes and the riser into the storage tank, and this process continues as long as the sun's radiation is strong enough to keep the collector plate hot." (96) The collector area needed to supply hot water to a 40-60 gallon storage tank is about 16-20 ft.², and the system produces hot water in temperatures ranging from 120° to 165°F.(97)

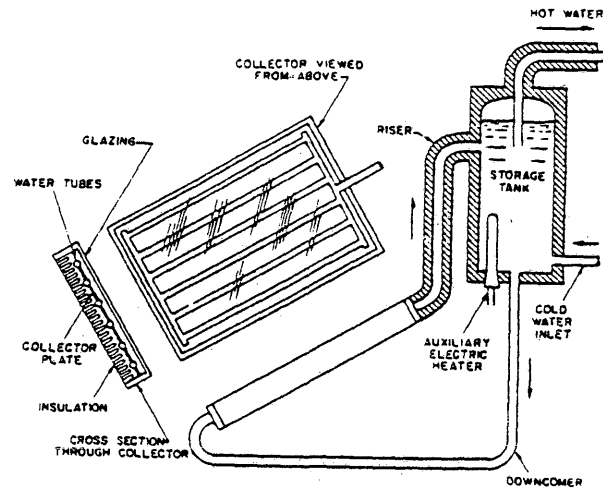

Courtesy of Heating/Piping/Air Conditioning (October 1966).

Figure 13. Thermosyphon Water Heater

Thermosyphon water heaters are widely used today in Australia and Israel, and were once used in Florida before natural gas became available.

Although thermosyphon water heaters have been used mostly in warm climates they can be adapted for use in cooler latitudes. On cold nights there is a chance of the syphon flow reversing, and water flowing downward into the heater, but this can be avoided by making sure that the storage tank is at least two feet above the top of the collector. In areas where freezing is a problem an indirect system using an antifreeze solution may be used in the collector, with heat transfer accomplished by a coil-type heat exchanger within the tank.

Often the hot water demands of a building cannot be met by a thermosyphon system or architectural constraints necessitate the location of the storage tank at some distance from the solar collectors. In this situation some means of forced circulation is needed to transport the water. In these systems centrifugal hot water accelerator pumps are used to move the water to the collectors, where it is pumped through and heated, returning to the storage tank via insulated pipes. With a larger array of collectors a much larger capacity is possible, and solar heated hot water can also be used to provide space heating when the hot water is pumped through a conventional hot water heating system.

Another attractive technology utilization for solar heaters is in heating swimming pools. Several methods have been proposed, including the integration of the collectors into the fence which is required around most swimming pools. In some part of California gas hookups for swimming pool heaters are no longer allowed, and it is hoped that the demand for pool heaters will be met with solar systems. The temperatures demanded are not very great, and many relatively inexpensive products are presently available.

Solar hot water systems have benefitted from a great deal of research and technology is highly developed. While this is not the case for solar powered forced-air heating

represents an attractive alternative, superior in some ways to water heating, in spite of the much lower specific heat of air. Solar air heating collectors are not subject to the same constraints as collectors which heat water. Air cannot freeze, and while air leaks can reduce system efficiency, they do not constitute the same problems as do water leaks. In addition, with air systems there is not the same possibility of contamination which exists in a water system using an antifreeze additive, such as ethylene glycol, in the transfer fluid. Finally, air heating systems are often desirable because in many heating and cooling systems it is the air which actually accomplishes the heating and cooling.

A third methodology for utilizing solar energy involves the use of focusing or concentrating collectors. In this way, much higher temperatures can be produced and work accomplished which is dependent on greater amounts of energy. The major drawback of concentrating collectors is that they can function to some extent with diffuse solar radiation. Concentrating collector systems also require some means of tracking the sun, and this is an expensive requirement. Different types of concentrating collectors were described in the last section, where it was pointed out that their major contribution to solar energy would be in the large scale power production.

Sensible Heat Storage

Two widely publicized storage systems which utilize sensible heat capacity are water and rock bed storage. Water storage systems employ a large insulated tank which is supplied with hot water when the solar collectors are operating. During the evening or during periods of cloudy weather the heated water stored in the insulated tank is drawn off to be used in the building. On clear days, when the solar collectors can supply more than the heat immediately required by the building, excess hot water is pumped into the tank, thus rebuilding storage. Water, with a specific heat of 1.0 Btu/degree F)(lb), is an excellent storage material for its weight and size, and is a logical alternative for solar hot water systems because no intermediate heat exchange is necessary (so long as pure water is used throughout the system).

When air is the medium of transfer in the solar system, beds of rocks provide a means of energy storage. Although the specific heat of rock is much lower, about 0.2 Btu/(degree F)(lb.), and the energy stored is much lower per unit of weight, beds of crushed rocks have a large surface area and provide a good transfer medium for hot air.

Dr. George O.G. Löff, head of the Solar Energy Research Laboratory at Colorado State University, has pioneered with

with this means of energy storage, and in a solar house in Denver two 18 foot high cylinders, each containing 11 tons of 2 to 2.5 inch gravel, were used to supply energy storage.

(98) A system combining both of these methods of heat storage has been constructed and in use for many years by Dr. Henry Thomason, a Washington, D.C. solar energy builder. Thomason, in his system, utilizes a solar collector to heat water which feeds into a 1600 gallon storage tank that is surrounded by 50 tons of river pebbles to provide additional insulation.

Heat-of-Fusion Storage: One of the major problems with sensible heat storage is that it requires great amounts of space to be devoted to energy storage. Storage based on a heat-of-fusion principle may eventually help to reduce this space requirement because it provides a means of storing much greater quantities of heat in a given weight and volume of material. A simple example of this principle is the manufacture of ice from water, which liberates 144 Btu/lb. in its change of state at 32°F. For energy storage in solar systems, several methods have been suggested for the use of sodium salts and nucleating agents, which absorb and liberate large amounts of energy in their state changes. One well known process proposed by Dr. Maria Telkes uses "Blauer's Salt" ($\text{Na}_2\text{SO}_4 \cdot 10\text{H}_2\text{O}$). (99) This salt melts

and freezes at 91.4°F with a heat-of-fusion at 108 Btu/lb. Glauber's salt is an especially attractive possibility because of its low cost. One characteristic of these salts is that a large surface area is needed to bring about the reaction, and the salt-hydrate mixtures are stored in long thin tubes. By using different salt-hydrate mixtures it will be possible to store both heat and cold in separate banks of tubes available for use as the weather determines.

Although heat-of-fusion storage systems show promise in their ability to reduce the space requirements of energy storage, "none of these technologies has proven dependable or consistent in performance over many cycles of heating and cooling and extended periods of time." (100) While continued development of heat-of-fusion storage systems may establish this technological alternative, the most practical and economic storage alternative at present appear to be in the utilization of sensible heat.

Solar Cooling Systems

The ability of solar thermal energy to accomplish cooling has been established for a long time, and several technologies exist for solar powered air cooling and refrigeration systems. In the past, successful designs have depended on the use of concentrating collectors to produce the high temperatures needed to run refrigeration equipment. Because of the high

cost of concentrating collectors, these systems were uneconomical. With the continual development of improved collectors and more advanced designs for cooling equipment, it is hoped that solar cooling will become an increasingly economic alternative. One factor which will aid this development is that the period of greatest cooling demand coincides with the period of maximum insolation, so the temperatures needed to power cooling equipment can be produced and directly applied to supplying cooling requirements.

Of the different schemes proposed for air cooling, the alternative with the greatest promise uses an absorption air conditioning cycle which is powered by solar heated water. Two different designs for this technology have been experimented with by Löff and Farber. Löff has used a commercially available absorption refrigeration system which utilizes water vapor as the refrigerant and lithium bromide as the absorbant in one of his solar homes.(101) With minor modifications to an Arkla-Servel 3-ton lithium bromide air conditioning unit, Löff and Ward were able to operate at close to 60 percent capacity of the 3-ton unit and supply the bulk of their cooling load.

Erich A. Farber, director of the Solar Energy Laboratory at the University of Florida, working with an ammonia-water absorption cycle, has developed "a continuous

refrigeration system in which the solar absorber is also the generator which drives the ammonia out of the water solution."(102) The attractiveness of this concept lies in the lower temperatures which are needed to power the unit, typically 180°-190°F. which are well within the temperature range of today's flat plate collectors. In spite of Farber's encouraging results, the cost of solar air cooling must be drastically reduced and the efficiency increased if it is to compete on a large scale with electrical air condition systems.

Other systems for natural cooling involve the utilization of nocturnal radiation to achieve cooling. This approach was widely used in the southwestern United States before the advent of electrically powered air conditioners. These systems rely on the transfer of heat in water to the cooler night sky, and can reduce interior temperatures, especially in areas of low humidity. In areas of high humidity there is little hope for natural cooling to accomplish much, and Yellott has said that "the high indoor humidities caused by direct evaporative cooling produce nearly as much discomfort as the high temperatures in which it operates."(103)

Combined Systems for Heating and Cooling

In a 1970 article, Löff and Tybout showed that a combined system for heating and cooling was more economically attractive than a system which does either function alone. (104) It is much easier to justify the costs of solar collectors when they can be operated throughout the year than if they are used only during the winter. Several different designs for integrated systems exist. Perhaps one of the simplest designs for heating and cooling is the Hay Skytherm house, discussed earlier, which uses a shallow roof pool with a movable insulation to cover to control desired temperatures. Thomason's system has also been mentioned, and a schematic diagram is shown in Figure 14. While often criticized for the low efficiencies inherent in open trough water flow, Thomason's system is very attractive from an economic viewpoint, with collector costs at approximately \$4.00 per square foot. In comparison, the forced air solar collector produced by Solaron Inc., and designed by George Löff, are currently in a \$17,000 price range.

Another integrated system is the "Solar One" house developed at the University of Delaware. Although an expensive prototype, Solar One was an attempt to utilize some of the developing solar technologies in a residential building. Cadmium sulfide photovoltaic cells have been incorporated

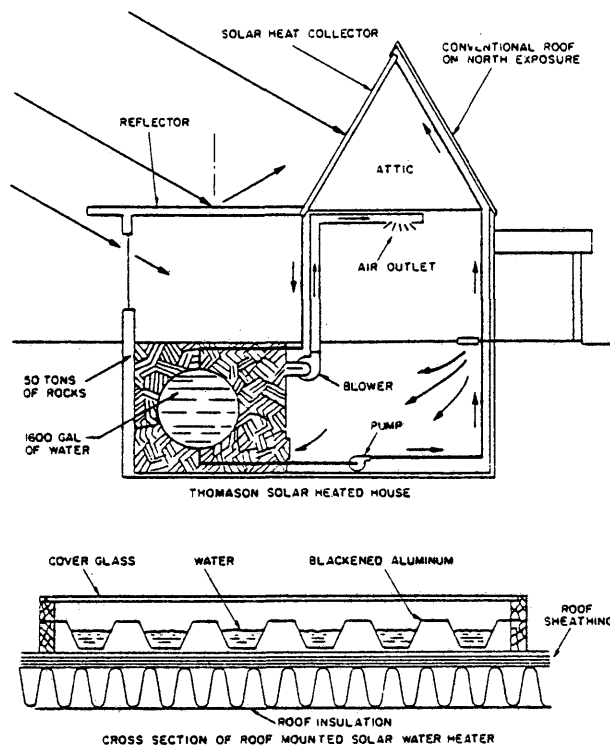

Courtesy of *Heating/Piping/Air Conditioning* (October 1966).
^a Heat storage is provided by 1600 gal water tank plus 50 tons of rocks.

Figure 14. Schematic Diagram of Thomason Solar Home

into solar collectors on the roof in an attempt to provide electricity for home use as well as space heating. Eutectic salts are being used as an energy storage medium, and it is hoped that Solar One will be able to supply 80 percent of its total energy needs directly from the sun. A fully integrated design for the heating and cooling of a building is shown in Figure 15. This concept, designed for a house with a winter heating and summer cooling load, is based on a solar water heating design which heats air for space

heating requirements. A conventional heating system is included, but used only when storage is depleted.

Economics

In spite of these attractive technologies, it is undoubtedly true that the future potential for a contribution of solar energy to our energy supply will depend on economics. Would-be consumers must make an economic decision as to whether or not to install solar equipment. Because a solar energy system can supply only 60 to 80 percent of the buildings energy demands, a back-up system is necessary, and the rationale for investing capital in a solar heating and/or cooling system must be weighed against the potential fuel savings which accrue to the solar system. These fuel savings, less maintenance costs on the solar equipment, constitute the positive cash flows which amortize the front-end costs of the system. Thus, before a solar energy system should be installed, a careful economic evaluation based on the life-cycle costs of the various systems must be made to determine which, if any, solar products should be utilized to make an economically justifiable system.

One factor which makes this evaluation difficult is that solar energy systems have a great variability in their economic attractiveness, depending on the given site and

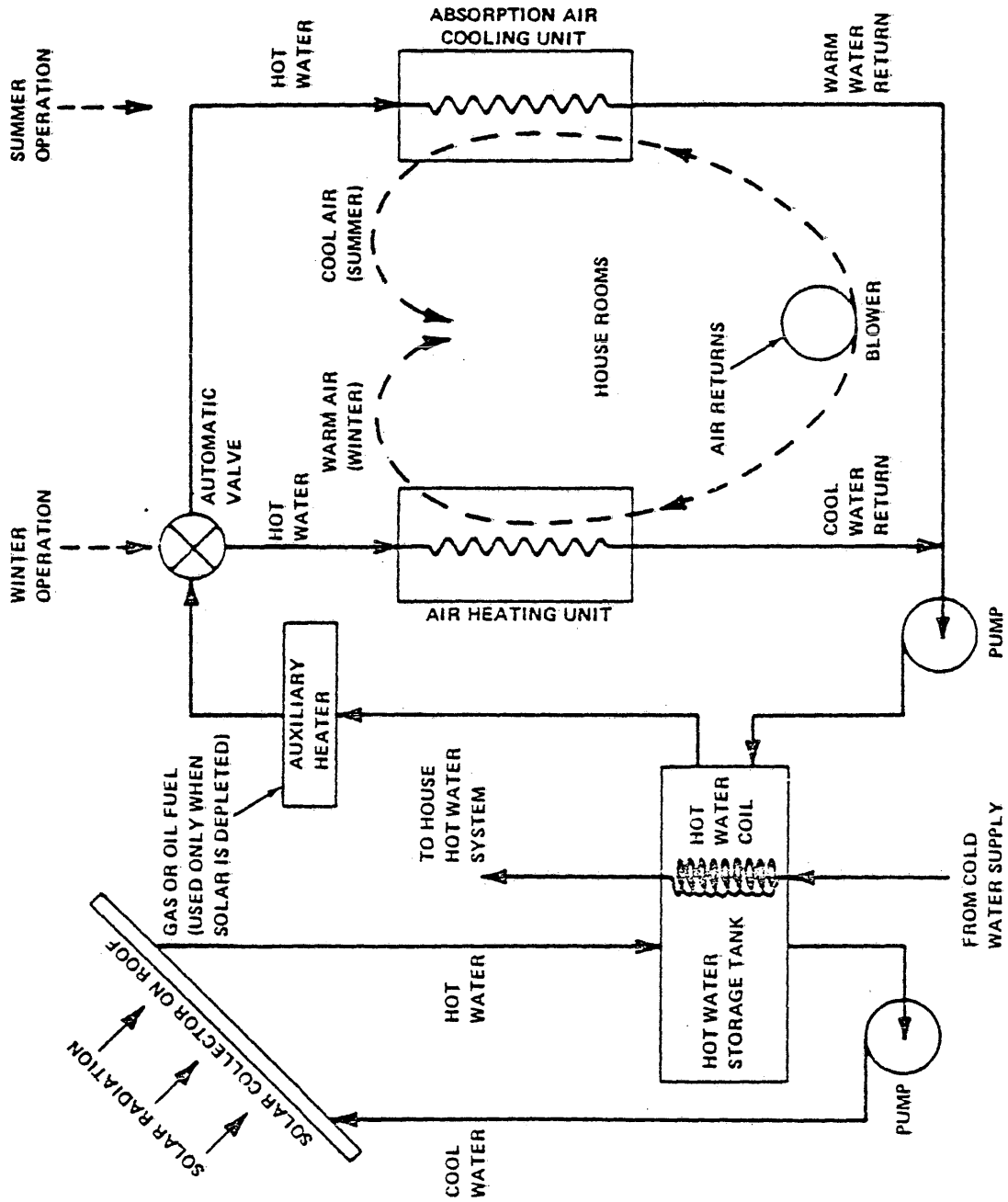

Figure 15: Integrated Design for Solar Heating and Cooling

location. A system which is economic in Atlanta, Georgia may not be desirable in Madison, Wisconsin, or even in another part of Georgia. Specific site characteristics, annual insolation data, number of clear days, and mean and diurnal temperature variations must be considered for each site if the best system is to be selected. This variability in climate and insolation, as well as the individual architectural constraints, necessitate that a great variety of solar equipment be available. Fortunately, this is one of the characteristics of the solar energy industry, which consists of many small entrepreneurial businessmen producing a great variety of products. But, while a different solution exists to almost every problem, there is the question of which system to use, and this must be individually determined for each site. In spite of the desirable load factors achieved by an integrated system for heating and cooling, often a solar hot water heater alone may be the most economic decision for a given location under present circumstances.

In whatever system is applied, the costs must be kept as low as possible because excessive front-end costs will discourage potential customers, no matter what fuel savings could accrue. Collector costs are usually the indicator of system cost, but may only represent 50 percent of the final sum. Storage systems and the degree of solar utilization add to the materials cost and the labor required for installation is also very expensive.

In addition to the front-end capital costs of a solar system, other factors should be considered in making an economic evaluation of this type. The expected annual maintenance charges, the percentage of heating and cooling supplied, and the expected annual fuel savings should also be carefully determined. Intangible concerns, such as becoming more independent from energy utilities or making a contribution towards relieving the energy shortage, are also important, but to a smaller degree. While these intangible factors may provide a source of motivation for the first consumers to employ solar energy systems, it is unlikely that concerns other than system cost, reliability, and expected fuel savings will encourage a large-scale development of solar technologies for commercial and residential use.

While realizing that any economic evaluation must be made for the individual site and proposed systems, an attempt is made here to put a bound on the cost of solar collection systems. It has been estimated by Hoyt C. Hottel, an expert on solar collector design from M.I.T., that each square foot of collector area can save between 100,000 and 250,000 Btu per year. This is equivalent to 1.0 and 2.5 gallons of oil per square foot per year, burned in a furnace which is 70 percent efficient.(105) This modest output by solar collectors necessitates that costs be kept low, and Hottel argues that:

If the investment in a flat-plate collector system is to be recovered within a reasonable period, the system cannot cost more per square foot than 10 times the yearly savings. When heating oil is the alternative, the limit for the complete system, counting collectors and storage, is therefore \$4.00-\$10.00 per square foot of collector surface. (This estimate based on oil costing \$.40/gallon).

In many parts of the country energy costs are much higher, especially where electrical resistance heating is the only alternative, and in these areas more expensive solar energy systems may be justified.

It is apparent, though, that solar energy systems for HCB are rapidly reaching the realm of economic feasibility. Systems such as Thomason's may represent the first really economical products. While collector costs presently range from about \$4.00 for the Thomason collector (before installation) to \$20.00-\$25.00 for "Owens-Illinois" high temperature, evacuated, "Sunpack" collector, it seems certain that costs will drop. As solar systems become more widely accepted, and conventional fuels continue to increase in price, the demand for these systems will grow. In response to this demand, mass production facilities will be built and collector costs will be greatly reduced by the economies of scale. In addition, the overall system cost will go down as storage problems are worked out, and as solar energy contractors gain production experience. Solar energy systems are at the dawning of their utilization and initial systems will necessarily be expensive, but there is good reason to expect

reduced costs as the industry grows. These improving economics will greatly enhance the competitive position of solar technologies and provide the means for considerable savings of conventional fuel sources.

BARRIERS TO THE UTILIZATION OF SOLAR ENERGY
FOR THE HEATING AND COOLING OF BUILDINGS

A great deal was said the last section about the potential for solar technologies to supply a significant amount of the energy used in commercial and residential space heating and cooling. It was established that the primary determinants of acceptability for solar systems would be economic in nature. At the same time, there are many other less obvious factors which could have an important effect on the rate at which solar technologies are utilized. In light of the recent surge in public enthusiasm for solar energy it is especially important to identify these constraints and to set up strategies for their removal so that we can avoid what Hottel has described as "a period of midsummer madness brought on by the sun." (107) These barriers to development fall into four general areas, social, technical, economic and political, and will be discussed in this section.

Social

Two recent studies which have sampled the public's attitude toward solar energy systems (SES) have been prepared

by Westinghouse and T.R.W. Systems Group under grants from the National Science Foundation's program, Research Applied to National Needs (RANN). These studies reported that in general people were favorably disposed to SESs, and 46 percent of those sampled by the T.R.W. study felt that solar energy would be "in general use in less than 10 years." (108) Another 44 percent felt that this would not happen until a 20-year time period had passed, while only about 10 percent thought that no significant contribution would be made. In each of the studies public enthusiasm was based on lower operating costs, savings of fossil fuels, and no pollution, which characterize SESs. As would be expected, enthusiasm was found to vary inversely to cost. Other concerns to prospective consumers included the problems associated with energy storage and system reliability.

Although the initial costs of solar equipment will always be higher than a heating and cooling system based on conventional components, much of the public reaction is due to an ignorance of life-cycle costing techniques for investments. Potential consumers are often overwhelmed at the high front-end costs, so for many the analysis stops there. SESs must be treated as investments and evaluated on this basis, and a successful marketing effort would have to emphasize the desirability of solar systems over a long period of time.

For this to occur, solar heating and cooling systems that are highly reliable will be needed. While most of the designs discussed in the literature have been extensively tested for durability of construction and long service life, problems will occur in the early stages of the solar products industry. This will be especially true if many new companies hurriedly produce solar components in an attempt to grab a market share of the growing demand. Some means of consumer protection, involving product standardization and quality insurance, must be developed in order to point out the differences between products if this problem is to be avoided. In addition, simpler products, with less complicated designs, that can be easily repaired or replaced would be favored, especially by individual homeowners.

Consumer movement into solar energy systems has also been hindered because of the difficulty of retrofitting existing buildings to accommodate solar equipment. Even if the building does have a good orientation to exploit the incoming solar radiation, it is usually very difficult and expensive to reorient the heating from the basement to the roof. Additional piping or heat ducts and storage are necessary, and hard to incorporate into an already finished building without major alterations. Therefore, the market for solar energy systems for buildings exists primarily

in new structures. Because the number of custom-built one-family dwellings is relatively small, the number of solar heated homes is very small.

The annual market for multi-family dwellings and public and commercial structures is quite large, and represents an area where SESs may have a major impact. In these buildings, the primary objectives are low maintenance and operating costs with a high degree of system reliability and long life, so that a somewhat higher initial cost can be justified. Public and commercial buildings are particularly well suited to solar energy utilization because their demand for space heating and cooling is primarily during the day, when solar insolation is available. This enables the utilization of a much smaller storage system. These buildings are usually much larger than single family residence, and will be able to take a greater advantage of wholesale purchasing of the collectors and other components.

The attitudes of different groups within the building trades will have perhaps the greatest effect in determining how rapidly solar energy technologies will be incorporated into society. The building trades have a long history of resistance to change, and great pressure is needed to bring any innovation into general use. This is true in the case of SESs and builders who were interviewed by the Westinghouse

study expressed a general reluctance about becoming involved with solar power.(109) While builders were not against the eventual use of solar technologies, no one wanted to be first to incorporate unproven solar designs in their buildings. Contractors were afraid that innovative solar equipment would raise the price of buildings and reduce their marketability. Architects, too, wanted to be cautious about pioneering with solar energy systems, although they generally favored building designs which could easily be converted to accomodate solar components.(110) Furthermore, both groups expressed a concern that without an extensive marketing effort consumers would tend to stick with conventional systems.(111)

Other problems within the construction industry might arise because of the lack of single-point product responsibility for solar energy systems. Because a solar component system is an integral part of both the building construction and the heating and cooling ventilation system "numerous trade groups would be involved or affected with the system installation, thereby making it difficult, if not impossible, to place the responsibility with a single contractor."(112) This problem could become especially serious when product warranties are a common feature for solar power systems.

Building codes represent another potential problem area. While the codes in general do not represent any basic obstacle to solar power utilization, the "absence of negative prohibitions does not necessarily equate to the presence of positive interpretations by the various local code bodies involved in the review and approval of construction projects."

(113) There are, then, no real incentives for solar energy within the building codes. Building codes have traditionally been prescriptive in nature so that they could be readily interpreted, but this structure does not allow for innovative technologies to be readily incorporated into building construction. A positive measure which could greatly aid solar energy development would be a switch to "performance-oriented" codes. Codes of this nature can establish, for example, maximum allowable heat losses for new buildings. This would greatly encourage energy conserving designs with good insulation to enable the utilization of innovative products.

While these "performance-oriented codes would not place conventional environmental comfort systems at any competitive disadvantage, it would be easier and less expensive for solar energy systems to satisfy reduced energy consumption requirements." (114) In this way building codes could supply a strong incentive to solar energy, which could result in accelerated development.

ARTHUR LAKES LIBRARY
COLORADO SCHOOL of MINES
GOLDEN, COLORADO 80401

Another important area of concern which architects must face is the aesthetic incorporation of solar equipment into conventionally popular building design. Although the physical incorporation of solar designs does not present any formidable structural problems, a successful solar home designer must attractively integrate energy equipment into overall design. One of the largest consumer fears about solar homes is that solar designs may encumber the future marketability of the house. Architects, as well as consumers, are already uncertain of the effect which the added expense will have on the resale values, and for their fears to be overcome attractive, well integrated designs will be essential.

A final area of concern to homeowners is the fear that the installation of energy saving solar equipment will drastically affect their taxes. At present this is the case in most states. Even though legislative movement to establish tax breaks for investors in home systems is under way in several states, this stands as a strong deterrent to potential consumers. This concern could be alleviated, and Duffie has stated that:(115)

Government encouragement to invest in solar energy systems in the form of tax write-offs or other incentives (as are provided for investments by other energy producers) could very rapidly change the competitive position of solar energy in relation to conventional energy sources.

Technical

Although the primary technical design problems have been solved for solar energy, there is still a great deal to be accomplished from a technical standpoint. As mentioned above, almost all solar energy systems installed to date have been one-of-a-kind designs, which has largely contributed to their high initial costs. Retrofitting, too, is a custom job, which, in most cases, is prohibitively expensive. There is a strong need, therefore, for technically standardized products if the costs of solar power systems are to significantly decrease. Furthermore, technical standards are badly needed to insure reliable and well manufactured products if any type of reputation for quality production is to develop.

Hand in hand with this need for standardization is a need for simplified designs wherever possible. Solar energy "packages" could eventually become an outgrowth of these simplified designs. Designed for easy installation by carpenters or project-minded homeowners, these systems could be set up to teach the homeowner something about his own home and energy consumption. This would cause a reduction in both installation and maintenance charges, and further reduce overall costs. Improved designs resulting in higher efficiencies for solar components, especially in energy storage systems, are also necessary before significant cost reductions are possible.

Economics

Undoubtedly the most important factor leading to reduced costs and to an enhanced economic position of solar energy systems is the adaptation of components, especially collectors, to mass production facilities. Products which can be easily fabricated by machine with a minimum of human labor will be subject to the greatest economies of scale and cost reductions of 50 percent are not unrealistic. Price reductions of this magnitude will greatly broaden the competitive base of solar products and speed solar development.

Two basic factors have hindered this move toward mass production. First has been the lack of well defined market studies which clearly indicate the market potential of solar products. As a result, financial institutions have been slow to move into solar energy investments. While members of most financial institutions are encouraging about the eventual demand for solar technologies, they are uncertain of the present market, and feel that the presently high costs may exhibit a strong moderating effect on the rate at which solar products are demanded. Also, because of a lack of extensive data on operating and capital costs, the financial institutions are skeptical of the product acceptability of solar components by consumers. In general, the lending institutions prefer to wait and see how successful government sponsored demonstration projects are before committing their own resources to solar energy development. (116)

A second factor which has slowed the development of mass production technologies for solar products has been the generally small nature of almost all solar energy businesses. Although many large companies are not becoming involved, the field of solar energy has been pioneered by small partnerships and one-man entrepreneurial undertakings. These small businesses have been unable to gather the broad-based support necessary to develop economies of scale, and there is a general fear among many small solar companies that they will be put out of business by the large companies who have benefitted so much from their years of experience. On the other hand, many small businesses have been able to grow with the increasing demand for solar products, and are preparing the preliminary work for a move into more automated production.(117) It is certainly possible, therefore, that many intermediate-sized solar energy companies can develop in different regions of the country, specializing in either manufacturing or installation of solar energy systems, or in both.

The acceptance of solar products and technologies may also be frustrated by other economic concerns. Because of the vast climatic differences across the United States the costs of solar heating and cooling vary greatly, depending on not only the location, but on the system employed and the

fuel cost of the conventional system. These variable economics make it difficult for consumers to get a clear picture of what solar energy can actually do. This problem is compounded by the vast number of solar energy components and systems which are available. By virtue of the number of alternatives which must be evaluated for each particular situation, the economic analysis is a very difficult job, which is further frustrated by the generally poor understanding of economic principles on the part of the consuming public.

The attitudes of public power utilities concerning solar energy users is also an important issue. For the most part, solar energy systems would ease the demand curve which power companies must satisfy, but for the periods when solar power is incapable of supplying the load, the public utility must maintain a high capacity. The higher cost of running at a lower overall load factor could raise the utility rates of solar power systems, and rates which decrease with higher energy use would disfavor solar energy users. It would be very unfortunate if solar power consumers were charged more for the savings they were helping to bring about, and there is a real need to evaluate the utility rates paid by solar powered homes.

Political

There is probably no group which will affect the rate at which solar energy systems are developed more directly than the Federal Government. Unfortunately, until the past five years the energy alternatives pursued by the United States government were almost exclusively anti-solar. The Paley Commission Report, prepared for President Truman in 1952, evaluated the future of America's energy needs. Considerable attention was given at that time to the potential of solar and nuclear energy as solutions for the future, with solar power being high favored. In spite of this call for support of solar energy, nuclear power was chosen by the government as the first priority. Duffie has suggested that this was because:(118)

There was no constituency pressuring for solar energy development in a matter similar to that of the nuclear industry that existed at the close of World War II and gave a substantial impetus to the development of peacetime uses of nuclear energy.

There was a great deal of high grade uranium left over at the end of the atomic bomb development program, and the industry was already becoming well organized. As more and more funds were sunk into nuclear power the government commitment became stronger, and solar energy received almost no funding during the 20 years between 1952 and 1971. Another indication of this nuclear predisposition within our government was brought to light in 1974, when it was

revealed that the Atomic Energy Commission had attempted to suppress the findings of the Eggers Panel Report on Solar Energy, which expressed very optimistic findings on the potential for solar energy systems.(119)

Although the last five years have seen a tremendous growth in interest for SESs, there are still many barriers to solar energy in government. Even though the federal budget for solar energy research and development is growing annually (1977 budget projected at about \$160 million), often these funds are not spent where the need is the greatest. Research funds often go to institutions which have worked on government contracts before, and government policy regarding project funding for solar energy has been widely criticized. One author has said:(120)

Some of the money is even now being spent on demonstrations of solar heating and cooling systems known to be overpriced and on what might be termed "technological welfare:" research on futuristic solar contrivances by surplus aerospace engineers. Much of the government money, moreover, has gone not to the small inventors and entrepreneurs who have done much of the innovating and taken most of the risks, but to large corporations, schooled in research grantsmanship.

This is indicative of the attitude expressed by most of the small businessmen who testified before the Senate Subcommittee on Small Business in its investigation on small business and solar energy. In two days of hearings the subcommittee

listened to report after report of how the National Science Foundation, the Atomic Energy Commission, and E.R.D.A. have frustrated the efforts of small businessmen to acquire federal aid for their research and development projects. It would be a great shame if government support of solar energy was limited to larger institutions while smaller business organizations bore the burden of development, and some steps must be initiated to insure participation by small businesses.

Another area where governmental policy will have an important input on the development of solar systems is in helping remove legislative encumbrances at all levels. The possibility of drafting performance-oriented building codes which would provide strong incentives to solar power installations has already been mentioned. Potential problems may also arise in local zoning laws which will need to be amended to protect "sun-rights," for otherwise a solar energy investor in a city environment might lose his power supply if a taller building were built which obstructed his incoming solar radiation. Government involvement on a state and national level in prescribing tax policies which encourage the extra investment for solar power systems could also make a positive contribution.

Probably the greatest factor limiting the more rapid development of solar energy systems is the lack of any major commitment to the solar alternative on the part of the federal government. In spite of our renewed interest in solar power only a few percent of our annual energy budget is devoted to research and development of this resource. The economic attractiveness of solar energy is continually improving relative to conventional fuels, but the time required for the integration of solar systems into general use could be greatly reduced with a more vigorous commitment to this alternative on all levels. If the United States is really concerned about the impending energy crunch, it makes very good sense to pursue energy in all forms as soon as possible and to search out potential barriers to development and replace them with strong incentives.

THE OUTLOOK FOR SOLAR ENERGY:
STRATEGIES FOR DEVELOPMENT

We have seen that the technology exists for the development of solar energy systems for heating and cooling of buildings, and that although refinements are needed, there are no technical barriers to the implementation of these systems. Moreover, the economics of solar energy systems are at a watershed point in terms of competition with other systems. If, as expected, conventional fuels continue their current price trends, there will be an increasing demand for solar power systems as operating costs become a more significant figure in heating and cooling designs. Increased demand for solar products will, in turn, bring about price reductions, which will further enhance the economic attractiveness of solar alternatives, and demand will continue to expand. In this way the public will move toward a greater utilization of solar power. This movement is expected by almost all sources to be very gradual at first, with an accelerating development as the technology becomes more widely accepted. Because of an increasing pressure on the short

supply of fossil fuels it is likely that solar heating and cooling systems will supply a significant portion of the energy demand for this sector by the year 2000, and perhaps sooner. The major problems in implementing this technology, then, will not be technical ones, but will come in introducing the technology to the public. The public must be convinced to invest its capital in solar energy before this demand will pick up, and this must be done by gearing the implementation of solar products and equipment to the public's need. This has been succinctly stated in one article:(121)

The reality is that solar energy is immediately available for practical, efficient application and that reinvention of the wheel is not necessary. What is necessary is a reorientation of our technological thinking towards production of solar energy systems and equipment and developing the mass production capacity and capability to meet the requirements of the consuming public.

Although the utilization of solar energy would develop on its own, the federal government can play a major role in accelerating the rate of this implementation. To date a great deal of solar energy research and development has been focused by the government, but the market for the products of this R&D will not be the government (as, for example, with defense contracts), but the public. The government, therefore, has some degree of responsibility in delivering the results of this research to the public. In order to insure that these technologies be efficiently transferred

to the public it is meaningful to examine and evaluate a "Technology Delivery System" (TDS) for solar energy.(122) The concept of a TDS has often been used before for implementing technological innovations into public use, as, for example, the U.S. Department of Agriculture did in setting up the Field Agent program to deliver technological information to farmers during the 1930s.

By carefully outlining a TDS it can be more readily seen where specific attention must be concentrated so that key barriers may be replaced with strong incentives. A generalized block diagram of a TDS for solar energy applications to heating and cooling within the private housing market is shown in Figure 16.(123) Although this diagram is simplified, ignoring commercial construction, the role of public utilities and other factors, it does present a model of the required interactions between the solar energy R&D performers and the other sectors. An examination of the diagram will reveal the various sectors of the solar energy industry and the interactions between them. For example, the public, through homebuilders and developers would create a demand for products needing a technological solution which would be supplied by the architect/engineering companies. The quality of this relationship determines how well the needs of the public are met. The solid lines

represent existing relationships among components of the TDS while the broken lines represent the lines of communication which need to be established or further developed.

From within the framework of the TDS it can be seen which incentives should be applied and where they should be applied to have the greatest effect on easing the implementation of innovative technologies into the private sector. Because an input on one part of the TDS may have no real effect on the whole, a successful approach will necessarily stimulate all areas of the TDS. Some of these aspects are presented here.

To spark development of a new technology the government may have to be the initial purchaser of the product, and federal demonstration projects may have a strong role in establishing the Proof of Concept to the public. Arthur A. Ezra, engineering program director at the National Science Foundation, has said:(124)

The purpose of such projects is to provide empirical data on production cost, performance, reliability, and public acceptance. If the primary company carrying out the demonstration project is capable of subsequently manufacturing and selling the new product, process or service to the public, the chances are much higher for technology utilization in the civilian marketplace.

This was the objective underlying the Heating and Cooling Demonstration Act of 1974 (public law 93-409), which is intended to stimulate public acceptance of solar component

systems, and to which a large portion of solar energy funding will be devoted during the next few years. It is hoped that during this time period most of the "bugs" in solar heating and cooling systems can be worked out with continually improving and more reliable systems being used so that fully refined products can be marketed to the general public.

Information dissemination is one of the most critical areas in the implementation of any new technology, and the means for information transfer is a necessary function for the success of a TDS. Communication must exist on all levels of the TDS for solar energy so that manufacturers and contractors can take advantage of government sponsored research, so that lending institutions can make well-considered decisions, and so that the public can understand more fully the role and potential of solar energy systems. Although important on all levels, information dissemination is probably most difficult to achieve at the public level, where it is especially critical. A large percentage of potential solar energy consumers do not have an accurate conception of the present capabilities of solar energy systems. Often solar energy is viewed as a panacea, and end all of our energy problems. It is very important that this misconception be cleared up, and consumers educated to the reality of solar power so that the implementation of solar

technologies can proceed with a minimum of adverse public sentiment. Probably the best means for this information dissemination would be a program similar to the field agent system, but for energy instead of agricultural advice.

While the costs of an effort of similar magnitude for energy information would most likely be too expensive, a smaller, more modern equivalent might be developed. Perhaps small regional energy offices, relying on printed information materials and phone lines, could provide the needed information outlet to the public.

Another area where government involvement may speed the delivery of solar technologies to the public is through federal cost-sharing programs. These programs are aimed at raising the level of risk that would be acceptable to companies deciding whether to go ahead and produce and market the results of their R&D work. Although there are possibilities for abuse of funds here, there are many occasions when significant research would have been abandoned had government cost-sharing grants not been available. An area where this cost sharing will be important to solar energy implementation will be in the mutual funding of demonstration projects from private and public sources. Because solar demonstrations projects are to be constructed on many different types of buildings, both public and private, there

is an incentive for the private sector to become involved, and cost-sharing projects could greatly increase the number of demonstration projects constructed. In addition, the economic commitment of private firms involved in cost sharing projects serves to further encourage the public and other businesses toward solar alternatives.

Loan guaranties and loan insurance provided by the federal government could also provide important incentives within the TDS for solar energy. As discussed in the last section, many financial institutions, while optimistic about the long range future for solar energy, were unwilling to incur any additional risks to help demonstrate the potential for solar energy. Loan guaranties and insurance could be used to stimulate the availability of funds from lending institutions to solar equipment manufacturers and installers by providing an additional measure of economic security. These incentives have been widely used in other situations where the federal government wishes to promote business activity, as in federal loans through the Small Business Administration to help finance small businesses, and could provide some economic support to emerging solar energy firms. These loan guaranties could also be applied through an agency such as the Federal Housing Authority to help provide the financing for individual homeowners who want to implement

solar technologies. In this way, these incentives could provide necessary support to more than one sector of the TDS, and help to speed up the involvement of financial institutions in the implementation of solar energy technologies. Legislative steps have already been taken in this direction, and the Housing and Community Development Act (PL 93-383) provides for loan guaranties to solar energy innovators.

The development of a testing facility for solar energy systems which could prescribe performance specifications and establish regulations to ensure their compliance would have an important effect on establishing the acceptability of this technology. At present there is no such facility, and no required specifications exist for solar equipment. If this emerging industry is to establish credibility and manufacture high quality products, certain standards must be prescribed for manufacturers to follow. A facility for testing new products and designs, such as exists at the National Bureau of Standards, could be employed to test products and determine meaningful performance specifications. These specifications would be based on the products tested and on R&D findings, and legislated so as to provide meaningful performance criteria for solar energy systems. Such a facility could either publicly supported or industry backed, perhaps by insurance companies in a manner similar

to the "Underwriters Laboratory", which sets performance standards for electrical components. The formation of a facility of this nature would engender public confidence and provide a framework of criteria for the entire industry to follow, and would greatly contribute to the implementation of this technology.

Legislative involvement on federal, state, and local governmental levels could also provide meaningful incentives to solar energy development. Tax policies which favored and did not penalize energy conserving designs, performance-oriented building codes, and zoning legislation which protected "sun-rights" would provide incentives to the public for the implementation of solar energy systems. Present statutes provide few incentives, and often discourage solar power development, and this situation needs to be reversed. Public acceptance and utilization incentives could supply the TDS for solar energy systems with a much broader base of support. Important legislation has already been initiated in several states providing motivation for solar power development, and this is a further indication of the growing public support for solar energy.

A reevaluation and possible restructuring of public utility rates could also supply incentives to solar energy development. If utility rates within the private sector,

which currently provide for lower rates with increased demand, were to be restructured to favor energy conservation practices and innovations, this could provide additional economic justification for the adoption of solar technologies. There will undoubtedly be difficulties in finding an appropriate solution to this problem, but it is important to enlist the support of public power suppliers in implementing solar innovations. While solar energy consumers may cause demand fluctuations at the power plant during periods of bad weather, they are still somewhat energy independent, and can adjust their consumption to periods of the day when demand is not at peak levels, conserving their storage for energy use during high demand periods. A scheme to enable this has been proposed by Anderson and Feldman, which employs a variable rate structure to calculate power costs.(125) A utility meter records power consumption, and charges are based on both amount of power demanded and the time of day the power is utilized. It is hoped that by using such "peak-load pricing" policies, incentives will be created for the shifting of power consumption to periods of reduced demand for for the implementation of solar energy technologies which reduce overall demand.

The technology delivery system for solar energy is re-drawn in Figure 17, with the inputs of several possible

ARTHUR LAKES LIBRARY
COLORADO SCHOOL of MINES
GOLDEN, COLORADO 80401

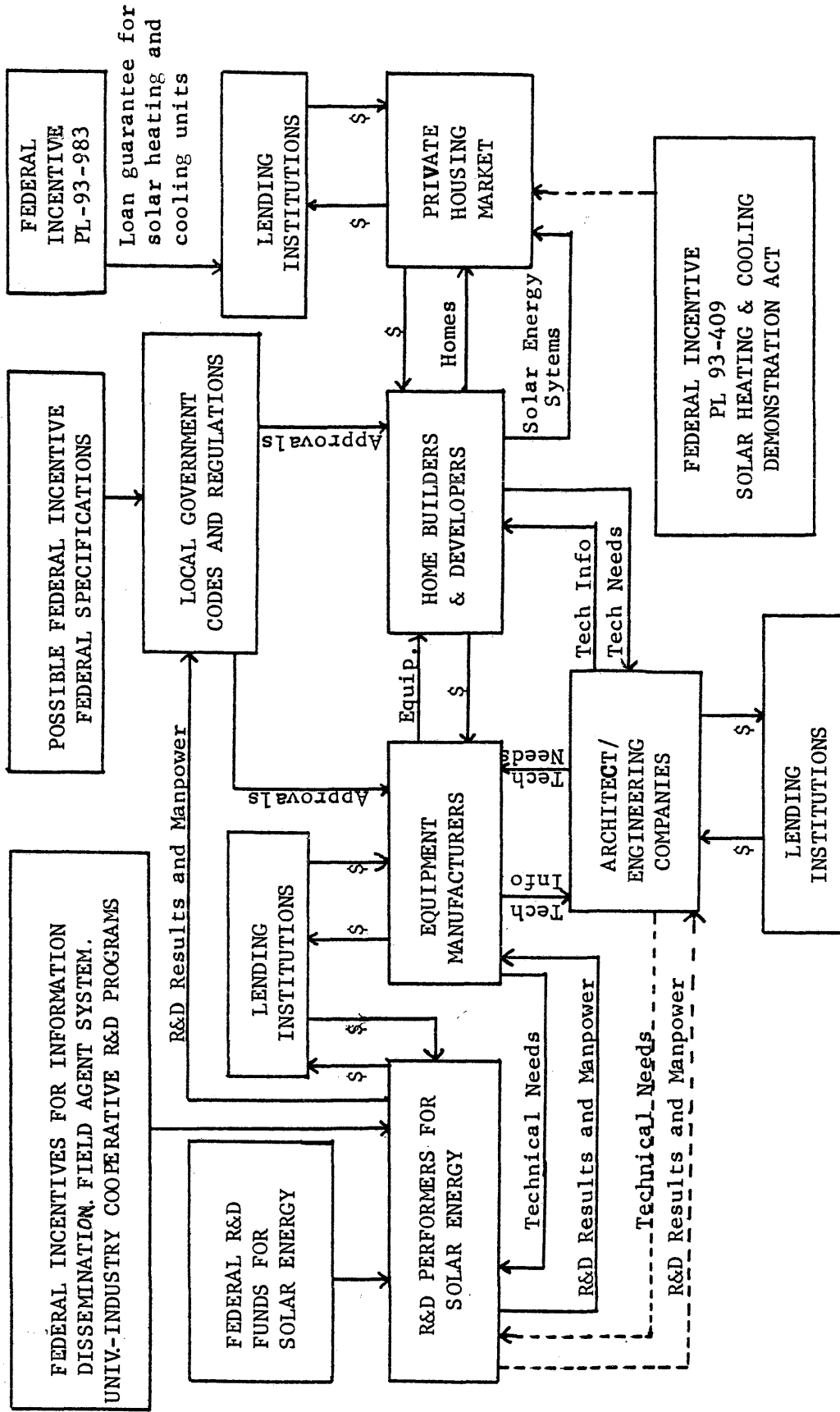

Figure 17: Technology Delivery System for Solar Energy Showing Possible Incentives (Broken lines indicate linkages to be established or strengthened)

incentives depicted. Incentives must be applied to each area of the TDS for there to be a major move towards accelerating technology implementation. Moreover, each component will require different incentives, and all incentives must be applied simultaneously for the TDS to have any prolonged effect. Even though the TDS is only a model, it can give a meaningful approximation of reality and can serve as an important tool in defining which areas need to be stimulated for technological implementation to occur.

It should be realized, however, that the successful development and use of a TDS for helping to bring innovations into public use is based on an active participation by the federal government in defining and providing incentives for development. Thus far the federal government has moved only very slowly toward removing barriers and creating incentives to solar energy development. Government involvement has largely originated from within Congress, and there has been virtually no outright support of solar energy technologies from the Executive Branch, when what was needed was a national commitment for the development of solar energy to follow up the plans for energy utilization laid out by the "Project Independence" reports.

Whether or not the Solar Energy Development Act of 1974 and other legislative incentives will foster a greater and more vocal support within the federal government for solar alternatives remains to be seen. The development of these technologies, though, is not dependent on government attitudes. The economic realities of rising fuel costs and fuel imports, along with diminishing domestic energy reserves, will eventually provide the necessary motivation for a widespread utilization of solar energy technologies. The question to be answered is not "if solar energy will be developed", but "how soon will it be before solar energy utilization is a necessity." The federal government has the means to greatly shrink the time lag by supplying the incentives necessary to accelerate technological implementation, or it can sit back and let the industry develop on its own. If this latter course of action is adopted, an economic cost must be incurred which is the value of the fossil and nuclear fuels which must be consumed while the solar energy industry develops on its own. It would seem that in light of the increasingly high value placed on our rapidly disappearing energy stocks this cost would appear to be too dear.

LITERATURE CITED

- (1) John Yellott, "Solar Energy Utilization for Heating and Cooling" Chapter 59 of the Applications Volume, A.S.H.R.A.E. Guide and Data Book, 1974 ed. (Washington, D.C.: U.S. Government Printing Office, 1974), p. 59.2.
- (2) Kenneth P. Maddox, "Solar Energy Conversion", Mineral Industries Bulletin, vol. 17, no. 5, (Sept. 1974), p. 1.
- (3) Farrington Daniels, Direct Use of the Sun's Energy, (New Haven: Yale University Press, 1964), p. 17.
- (4) Yellott op.cit., p. 59.2.
- (5) Ibid., p. 59.2.
- (6) Ibid.
- (7) Daniels, op.cit., p. 17.
- (8) Ibid.
- (9) Ibid., p. 15.
- (10) Frank von Hippel and Robert A. Williams, "Solar Technologies", Bulletin of the Atomic Scientist, November 1975, p. 25.
- (11) Ibid.
- (12) Ibid.
- (13) Maddox, op.cit., p. 4.
- (14) Daniels, op.cit., p. 5.
- (15) "The Solar Furnace at Odiello", C.N.R.S. Research, no. 2, 1975, p. 22.

- (16) Henry Simmons, The Economics of America's Energy Future, (Washington, D.C.: U.S. Energy Research and Development Administration, 1975), p. 11.
- (17) "An assessment of Solar Energy as a National Energy Resource", National Science Foundation/National Aeronautics and Space Administration Solar Energy Panel, 1972, p. 2.
- (18) U.S. Department of the Interior, Energy Perspectives, (Washington, D.C.: U.S. Government Printing Office, Feb. 1975), p. 33.
- (19) NSF/NASA Report op.cit., p. 18.
- (20) "Solar Heating is Here and Booming", U.S. News and World Report, March 29, 1976, p. 30.
- (21) NSF/NASA Report op.cit., p. 1.
- (22) Von Hippel op.cit., p. 27.
- (23) NSF/NASA Report op.cit., p. 49.
- (24) Maddox, op.cit., p. 12.
- (25) Ibid. pp. 10-11.
- (26) Ibid. p. 11.
- (27) Ibid. pp. 12-13
- (28) Von Hippel op.cit., p. 27.
- (29) NSF/NASA Report, op.cit., p. 48.
- (30) Von Hippel, op.cit., p. 27.
- (31) Energy Alternatives: A Comparative Analysis, (Washington, D.C.: U.S. Government Printing Office, 1975), p. 11.25.
- (32) Anita Gunn, "A Citizens Handbook on Solar Energy", (Washington, D.C.: Public Interest Research Group, 1975), p. 1-17.
- (33) Energy Alternatives, op.cit., p. 11.25.

- (34) Von Hippel, op.cit., p. 27.
- (35) Ibid., p. 27.
- (36) Ibid.
- (37) Von Hippel, op.cit., p. 28.
- (38) Gunn, op.cit., p. 1-18.
- (39) Gunn, op.cit., p. 1-15.
- (40) Maddox, op.cit., p. 6.
- (41) "Solar Energy is Here and Booming", op.cit., p. 31.
- (42) Daniels, op.cit., p. 208.
- (43) Bruce Chalmers, "The Photovoltaic Generation of Electricity", Scientific American, Volume 235, no. 4, October 1976, p. 41.
- (44) Edmund Faltermayer, "Solar Energy is Here, But It's Not Yet Utopia", Fortune, February 1976, p. 116.
- (45) E.L. Ralph, "Large Scale Solar Electric Power Generation", Solar Energy, vol. 14, 1972, pp. 11-20 passim.
- (46) P.E. Glaser, "Satellite Solar Power Station", Solar Energy, vol. 12, 1968, pp. 357.
- (47) NSF/NASA Report, op.cit., p. 63.
- (48) Von Hippel, op.cit., p. 29.
- (49) NSF/NASA Report, op.cit., pp. 62-63.
- (50) Ibid., p. 68.
- (51) D. Brunt, Physical and Dynamic Meteorology (New York: Cambridge University Press, p. 287), in Energy Alternatives, op.cit., p. 11.15.
- (52) E.C. Kung, "Large Scale Balance of Kinetic Energy in the Atmosphere", Monthly Weather Review, no. 94, Nov. 1966, p. 635, in Ibid., p. 11.15.

- (53) Von Hippel, op.cit., p. 68.
- (54) Energy Alternatives, op.cit., p. 11.15.
- (55) Von Hippel, op.cit., p. 29.
- (56) Energy Alternatives, op.cit., p. 11.17.
- (57) R. Ramakumar, et.al., "Prospects for Tapping Solar Energy on a Large Scale", Solar Energy, vol. 16, 1974, pp. 109-110.
- (58) Von Hippel, op.cit., p. 29.
- (59) Energy Alternatives, op.cit., p. 11.19.
- (60) Ibid., p. 11.19.
- (61) Ibid., p. 11.15.
- (62) NSF/NASA Report, op.cit., p. 68.
- (63) Project Independence: Final Task Force Report--Solar Energy, (Washington, D.C.: U.S. Government Printing Office, 1975), p. V-1.
- (64) Ibid., p. V-3.
- (65) Ibid., p. V-6.
- (66) Ibid., p. V-13, V-14.
- (67) Daniels, op.cit., pp. 241-242.
- (68) Ibid., p. 242.
- (69) Ibid.
- (70) Ibid., p. 248.
- (71) M.M. Eisenstadt and K.E. Cox, "Hydrogen Production from Solar Energy", Solar Energy, vol. 17, no. 1, 1975, pp. 59-65 passim.
- (72) Ibid., p. 62.
- (73) Ibid., pp. 59-65.

- (74) Ramakumar, op.cit., pp. 107-115.
- (75) Ibid., p. 108.
- (76) Ibid., p. 112.
- (77) Ibid., p. 109.
- (78) John A. Duffie and W.A. Beckman, "Solar Heating and Cooling", Science, vol. 191, 19.4223, January 16, 1976, p. 143.
- (79) "Solar Energy is Here and Booming", op.cit., p. 2.
- (80) NSF/NASA Report, op.cit., p. 18.
- (81) Faltermayer, op.cit., p. 104.
- (82) Yellott, op.cit., p. 59.10.
- (83) Ibid., p. 59.11
- (84) Ibid.
- (85) Ibid.
- (86) Daniels, op.cit., p. 150.
- (87) Yellott, op.cit., p. 59.12.
- (88) Daniels, op.cit., p. 151.
- (89) Yellott, op.cit., p. 59.12.
- (90) Ibid.
- (91) Ibid., p. 59.13.
- (92) Ibid.
- (93) Maddox, op.cit., p. 8.
- (94) Yellott, op.cit., p. 59.14.
- (95) Ibid., p. 59.13.
- (96) Ibid., p. 59.14.

- (97) Ibid.
- (98) Ibid., p. 59.16.
- (99) Ibid.
- (100) Westinghouse Electrical Corp., "Solar Heating and Cooling of Buildings: Phase O", (Washington, D.C.: National Science Foundation, May 1974), pp. 31.33.
- (101) G.O.G. Lof and Dan S. Ward, "Design and Construction of a Residential Heating and Cooling System:", Solar Energy, vol. 17, no. 1, 1975, pp. 13-20.
- (102) Yellott, op.cit., p. 59.17.
- (103) Ibid., p. 59.18.
- (104) G.O.G. Lof and R.A. Tybout, "Solar House Heating", Natural Resources Journal, vol. 10, no. 2, April 1970, p. 283.
- (105) Faltermayer, op.cit., p. 105.
- (106) Ibid., p. 105.
- (107) Faltermayer, op.cit., p. 105.
- (108) TRW Systems Group, "Solar Heating and Cooling of Buildings", Volume 1, Executive Summary, (Washington, D.C.: National Science Foundation, 1974), p. 4-1.
- (109) Westinghouse, op.cit., p. 50.
- (110) "Profession and Industry Focus in on Solar Energy", Architectural Record, August, 1975, p. 81.
- (111) Westinghouse, op.cit., p. 50.
- (112) TRW Systems Group, op.cit., p. 4-7.
- (113) Westinghouse, op.cit., p. 52.
- (114) TRW Systems Group, op.cit., p. 4-5.
- (115) Duffie and Beckman, op.cit., p. 143.

- (116) Paul D. Twombly, "Investment Possibility of Financial Institutions in Solar Heating", (Springfield, Va.: National Technical Information Service: U.S. Department of Commerce, 1974), pp. 56-60 *passim*.
- (117) John Bayless, President of Solaron Corp., Denver, Colorado, personal communication, April 1976.
- (118) Duffie and Beckman, op.cit., p. 144.
- (119) Alan J. Hammond, "Solar Energy Reconsidered: ERDA Sees Bright Future", Science, vol. 189, August 18, 1975, p. 538.
- (120) Faltermayer, op.cit., p. 116.
- (121) "Solar Energy in the Real World of How to Get Hot Without Getting Burned", by Sunsource, Inc., in Energy Research and Development and Small Business, testimony presented before the Select Committee on Small business, U.S. Senate, (Washington, D.C.: U.S. Government Printing Office, 1975), vol. I-B, p. 2085.
- (122) Much of this discussion is based on an article by Arthur A. Ezra, "Technology Utilization: Incentives and Solar Energy", Science, vol. 187, no. 4178, February 28, 1975, pp. 707-713.
- (123) Ibid., p. 712.
- (124) Ibid., p. 709.
- (125) Bruce Anderson and Stephen Feldman, "Financial Incentives for the Adoption of Solar Energy Design: Peak-load Pricing of Back-up Systems", Solar Energy, vol. 17, no. 6, 1975, pp. 339-343, *passim*.

BIBLIOGRAPHY

BOOKS

Anderson, Bruce, Solar Energy in Building Design, Cambridge, Mass., Arthur D. Little & Co., 1975.

Daniels, Farrington, Direct Use of the Sun's Energy, New Haven: Yale University Press, 1964.

Proceedings of the World Symposium on Applied Solar Energy, Phoenix, Arizona. Menlo Park, California: Stanford Research Institute, 1956.

PERIODICALS

Anderson, Bruce and Feldman, Stephen L., "Financial Incentives for the Adoption of Solar Energy Design: Peak-Load Pricing of Back-up Systems". Solar Energy, vol. 17, no. 6, 1975.

Bliss, Raymond W., "Why Not Just Build the House Right in the First Place?" The Bulletin of the Atomic Scientist, March 1976

Boffey, Phillip M., "Solar Research Sweepstakes: States Vie for a Place in the Sun", Science, vol. 190, October 10, 1975.

Chalmers, Bruce, "The Photovoltaic Generation of Electricity," Scientific American, vol. 235, no. 4, October 1976.

Chatel, Bertrand H., "New Potentialities for International Cooperation in the Field of Solar Energy and its Applications". Solar Energy, vol. 18, no. 1, 1976.

Duffie, John A. and Beckman, William A., "Solar Heating and Cooling", Science, vol. 191, no. 4223, January 16, 1976.

Eisenstadt, M.M. and Cox, K.E., "Hydrogen Production from Solar Energy". Solar Energy, vol. 17, no. 1, 1975.

- Ezra, Arthur A., "Technology Utilization: Incentives and Solar Energy". *Science*, vol. 187, no. 4178, February 28, 1975.
- Faltermayer, Edmund, "Solar Energy is Here, but it's not yet Utopia", *Fortune*, February 1976.
- Farber, Erich A., "Solar Energy, its Conversion and Utilization". *Solar Energy*, vol. 14, 1972.
- "Federal Energy Research Agency Invites Proposal for Scaled-Down Solar Institute". *The Wall Street Journal*, March 16, 1976.
- Gillette, Robert, "Breeder Reactor Debate; The Sun Also Rises". *Science*, vol. 184, May 10, 1974.
- Glaser, P.E., "Satellite Solar Power Station". *Solar Energy*, vol. 12, 1969.
- Hammond, Allen L., "Solar Energy Reconsidered: ERDA sees Bright Science", vol. 189, August 15, 1975.
- Lof, G.O.G., Close, D.J., and Duffie, J.A., "A Philosophy for Solar Energy Development". *Solar Energy*, vol. 12, 1968.
- Lof, G.O.G., Tybout, R.A., "Solar House Heating", *Natural Resources Journal*, vol. 10, no. 2, April 1970.
- Maddox, Kenneth P., "Solar Energy Conversion". *Mineral Industries Bulletin*, vol. 17, no. 5, September 1975.
- "Profession and Industry Focus on Solar Energy", *Architectural Records*, August, 1975.
- Ralph, E.L., "Large Scale Solar Electric Power Generation". *Solar Energy*, vol. 14, no. 1, 1972.
- Ramakumar, R., Allison, A.J., and Hughes, W.L., "Prospects for Tapping Solar Energy on a Large Scale". *Solar Energy*, vol. 16, no. 2, 1974.
- Sheridan, Norman R., "Criteria for Justification of Solar Energy Systems", *Solar Energy*, vol. 13, no. 5, 1972.
- "The Solar Furnace at Odeillo". C.N.R.S. Research, (Centre National de la Recherche Scientifique), no. 2, 1975.

"Solar Energy Systems: The Practical Side", Architectural Record. Mid-August 1975.

"Solar Heating is Here and Booming", U.S. News and World Report, vol. LXXX, no. 13, March 29, 1976.

Sorenson, Bent., "Energy and Resources", Science, vol 189, no. 4199, July 25, 1975.

"U.S. is Expanding National Program for Solar Energy", The Wall Street Journal, April 6, 1976.

Von Hippel, Frank, and Williams, Robert H., "Solar Technologies", Bulletin of the Atomic Scientists, November 1975.

Zoshak, R.J. and Wu, S.F., "Studies of the Direct Input of Solar Energy to a Fossil-Fueled Central Station Steam Power Plant", Solar Energy, vol. 17, no. 3, 1975.

PUBLIC DOCUMENTS

Energy Alternatives: A Comparative Analysis, prepared by the Science and Public Policy Program, University of Oklahoma, Norman, Oklahoma, Washington, D.C.: U.S. Government Printing Office, May, 1975.

Energy, Environment, Productivity, proceedings of the first symposium on R.A.N.N. (Research Applied to the National Needs) Washington, D.C.: U.S. Government Printing Office, November 18-20, 1973.

Energy Research and Development and Small Business, Hearings before the select committee on Small Business, United States Senate, 94th Congress, Washington, D.C.: U.S. Government Printing Office, May 13, 14, 1975, vols. 1.1-A, 1-B, 1-C, 1-D.

"ERDA Rates 36 Solar Systems Acceptable for Demonstration". Press Release no. 76-30. Washington, D.C.: Energy Research and Development Administration, February 4, 1976.

Gunn, Anita, A Citizens Handbook on Solar Energy, Washington, D.C.: Public Interest Research Group 1975.

National Science Foundation/National Aeronautics and Space Administration Solar Energy Panel, An Assessment of Solar Energy as a National Energy Resource, College Park, Md.: University of Maryland, 1972.

Resources for Freedom, Report to the President by the President's Materials Policy Commission (The Paley Commission), Washington, D.C.: U.S. Government Printing Office, June 1952, vols. 1-5.

Simmons, Henry, "The Economics of America's Energy Future", Washington, D.C.: U.S. Energy Research and Development Administration, 1975.

Task Force Report--Solar Energy, Federal Energy Administration Project Independence Blueprint, Under direction of the National Science Foundation, Washington, D.C.: U.S. Government Printing Office, November 1974.

TRW Systems Group, Solar Heating and Cooling of Buildings--Phase 0. Springfield, Va.: National Technical Information Service, May 1974, Volume I, Executive Summary.

Twombly, Paul D., Investment Possibility of Financial Institutions in Solar Heating. Springfield, Va., National Technical Information Service, U.S. Department of Commerce, June 1974.

U.S. Department of the Interior, Energy Perspectives, Washington, D.C.: U.S. Government Printing Office, February 1975.

U.S. Congress, Senate, Senator Thomas McIntyre speaking on the role of small business in solar energy development, 94th Congress, December 15, 1975. Congressional Record, CXXI, 185.

Westinghouse Electric Company--Special Group. Solar Heating and Cooling of Buildings--Phase 0. Springfield, Va.: National Technical Information Service, U.S. Department of Commerce, May 1974, Executive Summary.

Yellott, John I., Solar Energy Utilization for Heating and Cooling, Originally published as Chapter 59 of the 1974 edition, Applications Volume of the ASHRE guide and data book series. Washington, D.C.: U.S. Government Printing Office, 1974.